

DK Indhold af motordelgruppen
SE Innehåll av motordelargruppen

	Ventilshims412 Ventilshims412
	Ventiler416 Ventiler416
	Tourmax knastkæder420 Tourmax kamkedjor420
	Tourmax bundkæder430 Tourmax transmissionskedjor430
	Kølertermostater432 Termostater432
	Plejlstangkit432 Vevstaksats432
	Nålelejer432 Nållager432

Stikord Sökord s. 2-5
Forhandlere Återförsäljare s. 6-9
Tøj/hjelme Kläder/ hjälmår s. 11
Dæk Däck s. 83
Olje Olja s. 115
Kæde/ tandhjul Kedjor/ drev s. 145
Bremser Broms s. 187
Låse Lås s. 347
Batteri Batterier s. 355
Pakninger Packningar s. 377
Motordele Motordelar s. 411
Lejer Lager s. 435
Karburator Förgasare s. 467
El-dele/ Tænding Elektriskt/ Tänding s. 509
Blinklygter Baglygter Belysning Baklygter s. 611
Lyddæmper Avgassystem s. 651
Støddæmper Støtdämpare s. 681
Luft/ oliefilter Luft/ oljafilter s. 711
Kobling Koppling s. 769
Kabler Wire s. 803
Styr/greb Styre/ handtag s. 829
Spejle og diverse Speglar och diverse s. 867
Bøger/ værktøj Böcker/ verktyg s. 893



✚ Ventil-shims
✚ Ventil-shims



VENTIL-SHIMS • 7.5 mm

			HONDA	KAWASAKI	SUZUKI	YAMAHA						
Varenr.	Ref.nr.	Str.	Model	Årg.	Model	Årg.	Model	Type	Varenr.	Årg.	DKK	SEK
139120	7.5-1.35	1.35	NX 250	88-90	KL 250 G1/G2	00-03	GSX-R 600 WN/WP	92-93	YZ 250 F	02-03	28,-	35,-
139121	7.5-1.40	1.40	CB1 400	89-90	KLX 250	94-96	GSX-R 600 V-Y	97-03	FZR 400	88-90	28,-	35,-
139122	7.5-1.45	1.45	CB 600 F	98-04	KLX 300 A2-A6	97-04	RF 600 RR	94-96	FZR 600	89-99	28,-	35,-
139123	7.5-1.50	1.50	CBR 600 F2	91-94	ZX 600 D/E	90-01	SV 650	99-03	FJS 600	01-03	28,-	35,-
139124	7.5-1.55	1.55	CBR 600 FE/SE/SJR	95-02	ZX 600 F	95-97	GSX-R 750 W (P-S)	93-95	FZS 600	98-03	28,-	35,-
139125	7.5-1.60	1.60	CR 600 F4	99-01	ZX 600	00-04	GSX-R 750 T-Y	97-00	YZR 600 R	95-01	28,-	35,-
139126	7.5-1.65	1.65	RVF 750 R	94	ZX 636	02	RF 900 RR	94-97	YZF-R6	97-03	28,-	35,-
139127	7.5-1.70	1.70	VF 750 C	94-03	EJ 650	98-03	GSX-R 1000	01-04	YZF 750 R	94-98	28,-	35,-
139128	7.5-1.75	1.75	VF 750 CD	95-96	ZX 750	91-01	GSX-R 1100 K1	01	FZR 1000	89-95	28,-	35,-
139129	7.5-1.80	1.80	VF 750 C	97-00	ZX 900 B	94-97	GSX-R 1100 W	93-98	GTS 1000	92-94	28,-	35,-
139130	7.5-1.85	1.85	VFR 750 F	90-97	ZX 900 C	98-99			YZF 1000 R	96-01	28,-	35,-
139131	7.5-1.90	1.90	VFR 750 R	90	ZX 900 E	00-03			YZF-R1	99-03	28,-	35,-
139132	7.5-1.95	1.95	VFR 800	98-03	ZR 1000	03-04			FZS 1000	01-04	28,-	35,-
139133	7.5-2.00	2.00	CB 900 F	02-03							28,-	35,-
139134	7.5-2.05	2.05	CBR 900 RR	93-03							28,-	35,-
139135	7.5-2.10	2.10	CBR 929 RR	00-01							28,-	35,-
139136	7.5-2.15	2.15	CB 1100 SF	00							28,-	35,-
139137	7.5-2.20	2.20	CB 1100 XX	97-03							28,-	35,-
139138	7.5-2.25	2.25	ST 1100 A	91-02							28,-	35,-
139139	7.5-2.30	2.30	ST 1300	02-04							28,-	35,-
139140	7.5-2.35	2.35	GL 1800	01-04							28,-	35,-
139141	7.5-2.40	2.40	NRX 1800 DA/DE	04							28,-	35,-
139142	7.5-2.45	2.45	NRX 1800 EA/EB	04							28,-	35,-
139143	7.5-2.50	2.50	FJS 600	01-03							28,-	35,-
139144	7.5-2.55	2.55									28,-	35,-
139145	7.5-2.60	2.60									28,-	35,-
139146	7.5-2.65	2.65									28,-	35,-
139147	7.5-2.70	2.70									28,-	35,-
139148	7.5-2.75	2.75									28,-	35,-
139149	7.5-2.80	2.80									28,-	35,-
139150	7.5-2.85	2.85									28,-	35,-
139151	7.5-2.90	2.90									28,-	35,-
139152	7.5-2.95	2.95									28,-	35,-
139153	7.5-3.00	3.00									28,-	35,-
139154	7.5-3.05	3.05									28,-	35,-
139155	7.5-3.10	3.10									28,-	35,-
139156	7.5-3.15	3.15									28,-	35,-
139157	7.5-3.20	3.20									28,-	35,-
139158	7.5-3.25	3.25									28,-	35,-
139159	7.5-3.30	3.30									28,-	35,-
139160	7.5-3.35	3.35									28,-	35,-
139161	7.5-3.40	3.40									28,-	35,-



✚ Juster dine ventiler.

Vi kan nu præsentere Ventil Shims i vores program. Du kan selv indstille dine ventiler med disse kvalitets Shims - til en utrolig lav pris.

✚ Justera din ventiler.

Vi kan nu presentera Ventil Shims i vårt program. Du kan själv ställa in dina egna ventiler med våra kvalitets Shims - till ett otroligt pris.

 Ventil-shims
 Ventil-shims



VENTIL-SHIMS • 9.5 mm

Varenr.	Ref.nr.	Str.	KAWASAKI		SUZUKI		YAMAHA		Type	Årg.	DKK	SEK
			Model	Årg.	Model	Årg.	Model	Årg.				
139070	9.5-1.35	1.35	ZX 750 H ZX-7	89-90	DR-Z 400 SY/S/E/SM	00-04	TT250 RL/RLC/RM/RMC	99-00	28,-	35,-		
139071	9.5-1.40	1.40	VN 800 A/B/C	95-04	LT-400	03-04	YZ 400 F K/L	98-99	28,-	35,-		
139072	9.5-1.45	1.45	ZX 1000 B ZX-10	88-90	GSX 600 F	92-97	YZ 426 F	00-01	28,-	35,-		
139073	9.5-1.50	1.50	ZR 1100 C ZRX	99-00	GSX-R 750	91-92	WR 426 F	01	28,-	35,-		
139074	9.5-1.55	1.55	ZX 1100 C/D ZX-11		TL 1000 S	97-03	TDM 850	92-93	28,-	35,-		
139075	9.5-1.60	1.60	ZX 1100 E/F GPZ		TL 1000 R	98-03			28,-	35,-		
139076	9.5-1.65	1.65	ZX 1200 A1/A2 ZX-12R		GSX 1000	91-92			28,-	35,-		
139077	9.5-1.70	1.70	ZR 1200		DL 1000	02-03			28,-	35,-		
139078	9.5-1.75	1.75			SV 1000	03-06			28,-	35,-		
139079	9.5-1.80	1.80			GSX 1300 R Hayabusa	99-03			28,-	35,-		
139080	9.5-1.85	1.85			GSX-R 1100 M/N	91-92			28,-	35,-		
139081	9.5-1.90	1.90							28,-	35,-		
139082	9.5-1.95	1.95							28,-	35,-		
139083	9.5-2.00	2.00							28,-	35,-		
139084	9.5-2.05	2.05							28,-	35,-		
139085	9.5-2.10	2.10							28,-	35,-		
139086	9.5-2.15	2.15							28,-	35,-		
139087	9.5-2.20	2.20							28,-	35,-		
139088	9.5-2.25	2.25							28,-	35,-		
139089	9.5-2.30	2.30							28,-	35,-		
139090	9.5-2.35	2.35							28,-	35,-		
139091	9.5-2.40	2.40							28,-	35,-		
139092	9.5-2.45	2.45							28,-	35,-		
139093	9.5-2.50	2.50							28,-	35,-		
139094	9.5-2.55	2.55							28,-	35,-		
139095	9.5-2.60	2.60							28,-	35,-		
139096	9.5-2.65	2.65							28,-	35,-		
139097	9.5-2.70	2.70							28,-	35,-		
139098	9.5-2.75	2.75							28,-	35,-		
139099	9.5-2.80	2.80							28,-	35,-		
139100	9.5-2.85	2.85							28,-	35,-		
139101	9.5-2.90	2.90							28,-	35,-		
139102	9.5-2.95	2.95							28,-	35,-		
139103	9.5-3.00	3.00							28,-	35,-		
139104	9.5-3.05	3.05							28,-	35,-		
139105	9.5-3.10	3.10							28,-	35,-		
139106	9.5-3.15	3.15							28,-	35,-		
139107	9.5-3.20	3.20							28,-	35,-		
139108	9.5-3.25	3.25							28,-	35,-		
139109	9.5-3.30	3.30							28,-	35,-		

VENTIL-SHIMS • 13 mm

Varenr.	Ref.nr.	Str.	KAWASAKI		Model	Årg.	Model	Årg.	Model	Type	Årg.	DKK	SEK
			Model	Årg.									
139179	13-2.05	2.05	KZ 550	80-83								34,-	43,-
139180	13-2.10	2.10	ZX 550	84-85								34,-	43,-
139181	13-2.15	2.15	ZR 550	90-93								34,-	43,-
139182	13-2.20	2.20	KZ 650	77-83								34,-	43,-
139183	13-2.25	2.25	KZ 700	84								34,-	43,-
139184	13-2.30	2.30	ZN 700 A LTD	84-85								34,-	43,-
139185	13-2.35	2.35	KZ 750	80-83								34,-	43,-
139186	13-2.40	2.40	ZR 750	91-93								34,-	43,-
139187	13-2.45	2.45	ZX/GPZ 750	83-85								34,-	43,-
139188	13-2.50	2.50	ZR 1100	92-94								34,-	43,-
139189	13-2.55	2.55	ZX/GPZ 1100	83-85								34,-	43,-
139190	13-2.60	2.60										34,-	43,-
139191	13-2.65	2.65										34,-	43,-
139192	13-2.70	2.70										34,-	43,-
139193	13-2.75	2.75										34,-	43,-
139194	13-2.80	2.80										34,-	43,-
139195	13-2.85	2.85										34,-	43,-
139196	13-2.90	2.90										34,-	43,-
139197	13-2.95	2.95										34,-	43,-
139198	13-3.00	3.00										34,-	43,-
139199	13-3.05	3.05										34,-	43,-
139200	13-3.10	3.10										34,-	43,-

- Stikord Sökord s. 2-5
- Forhandlere Aterförsäljare s. 6-9
- Töj/hjelme Kläder/hjälm s. 11
- Däck Däck s. 83
- Olie Olja s. 115
- Kæde/tandhjul Kedjor/drev s. 145
- Bremser Broms s. 187
- Låse Lås s. 347
- Batteri Batterier s. 355
- Pakninger Packningar s. 377
- Motordele Motordele s. 411**
- Lejer Lager s. 435
- Karburator Förgasare s. 467
- El-dele/Tænding Elektriskt/Tænding s. 509
- Blinklygter Baglygter Belysning Baklygter s. 611
- Lyddæmper Avgassystem s. 651
- Støddæmper Støtdæmpare s. 681
- Luft-/oliefilter Luft-/oljefilter s. 711
- Kobling Koppling s. 769
- Kabler Wire s. 803
- Styr/greb Styre/handtag s. 829
- Spejle og diverse Speglar och diverse s. 867
- Bøger/værktøj Bøcker/verktyg s. 893

✚ Ventil-shims
✚ Ventil-shims



VENTIL-SHIMS • 25 mm

			HONDA		YAMAHA		TRIUMPH				
Varenr.	Ref.nr.	Str.	Model	Årg.	Model	Årg.	Model	Type	Årg.	DKK	SEK
139040	25-2.30	2.30	CB 750 C/F/K/SC	79-83	SRX 250 T/TC	87	Alle vandkølede			34,-	43,-
139041	25-2.35	2.35	CB 900 C/F	80-82	XT 250 L/LC	82-84	3- & 4-cyl. modeller.			34,-	43,-
139042	25-2.40	2.40	CBX 1000	79-82	TT 350/XT 350	86-00				34,-	43,-
139043	25-2.45	2.45	CB 1100 C/1100 F	83	XJ 600 Seca II	92-93				34,-	43,-
139044	25-2.50	2.50			XJ 600 N	00-02				34,-	43,-
139045	25-2.55	2.55			XJ 900 S	95-02				34,-	43,-
139046	25-2.60	2.60			FJ 1100/1200	84-93				34,-	43,-
139047	25-2.65	2.65			XJR 1200	95-98				34,-	43,-
139048	25-2.70	2.70			VMX 12/V-MAX	85-03				34,-	43,-
139049	25-2.75	2.75			XVZ 12/13	82-02				34,-	43,-
139050	25-2.80	2.80			XVZ 1300 Royal Star	96-02				34,-	43,-
139051	25-2.85	2.85			XJR 1300	99-02				34,-	43,-
139052	25-2.90	2.90								34,-	43,-
139053	25-2.95	2.95								34,-	43,-
139054	25-3.00	3.00								34,-	43,-
139055	25-3.05	3.05								34,-	43,-
139056	25-3.10	3.10								34,-	43,-
139057	25-3.15	3.15								34,-	43,-
139058	25-3.20	3.20								34,-	43,-

VENTIL-SHIMS • 29 mm

			KAWASAKI		YAMAHA		BMW				
Varenr.	Ref.nr.	Str.	Model	Årg.	Model	Årg.	Model	Type	Årg.	DKK	SEK
139000	29-2.00	2.00	KL 600	84-01	XS 400 J/K	82-83	K-100			34,-	43,-
139001	29-2.05	2.05	KL 650	84-01	XS 400 RJ/RK	82-83				34,-	43,-
139002	29-2.10	2.10	KLX 650	93-96	XJ 550 H/J/K	81-83				34,-	43,-
139003	29-2.15	2.15	Z1/KZ 900	73-76	XJ 550 RH/RJ/RK	81-83				34,-	43,-
139004	29-2.20	2.20	KZ 1000	77-85	XJ 600	84>				34,-	43,-
139005	29-2.25	2.25	KZ 1000 Police	82-97	FJ 600 L/LC/N/NC	84-85				34,-	43,-
139006	29-2.30	2.30	KZ 1100	82-97	FZ 600	86-88				34,-	43,-
139007	29-2.35	2.35	ZN 1100	77-85	YX 600	86-90				34,-	43,-
139008	29-2.40	2.40	KZ 1300	79-82	XJ 650 G/H/J/K	80-83				34,-	43,-
139009	29-2.45	2.45	ZN 1300	83-88	XJ 650 LH	81				34,-	43,-
139010	29-2.50	2.50			XJ 650 RJ	82				34,-	43,-
139011	29-2.55	2.55			XJ 650 LJ/LK	82-83				34,-	43,-
139012	29-2.60	2.60			XJ 750 J/K	82-83				34,-	43,-
139013	29-2.65	2.65			XJ 750 MK	83				34,-	43,-
139014	29-2.70	2.70			XJ 750 RH/RJ/RK	81-83				34,-	43,-
139015	29-2.75	2.75			XS 750 D/2D/YE/F	77-79				34,-	43,-
139016	29-2.80	2.80			XS 750 SE/SF	78-79				34,-	43,-
139017	29-2.85	2.85			XS 850 G/H	80-81				34,-	43,-
139018	29-2.90	2.90			XS 850 LG/SG/SH	80-81				34,-	43,-
139019	29-2.95	2.95			XJ 900 RK	82				34,-	43,-
139020	29-3.00	3.00			XJ 1100 J	82				34,-	43,-
139021	29-3.05	3.05			XS 1100 E/F/G/H	78-81				34,-	43,-
139022	29-3.10	3.10			XS 1100 LG/LH	80-81				34,-	43,-
					XS 1100 SF/SG/SH	79-81				34,-	43,-

VENTIL-SHIMS • 29,5 mm

			SUZUKI								
Varenr.	Ref.nr.	Str.	Model	Årg.	Model	Årg.	Model	Type	Årg.	DKK	SEK
139162	29.5-2.30	2.30	GS 400	77-79						34,-	43,-
139163	29.5-2.35	2.35	GS 425	80						34,-	43,-
139164	29.5-2.40	2.40	GS 450	80-88						34,-	43,-
139165	29.5-2.45	2.45	Gs 500	89-97						34,-	43,-
139166	29.5-2.50	2.50	GS 550	77-83						34,-	43,-
139167	29.5-2.55	2.55	GS 650	81-85						34,-	43,-
139168	29.5-2.60	2.60	GR 650 D/XD							34,-	43,-
139169	29.5-2.65	2.65	GS 750	77-82						34,-	43,-
139170	29.5-2.70	2.70	GS 850	79-81						34,-	43,-
139171	29.5-2.75	2.75	GS 1000	78-82						34,-	43,-
139172	29.5-2.80	2.80	GS 1100	79-82						34,-	43,-
139173	29.5-2.85	2.85	XN 85							34,-	43,-
139174	29.5-2.90	2.90								34,-	43,-
139175	29.5-3.00	3.00								34,-	43,-
139176	29.5-3.05	3.05								34,-	43,-
139177	29.5-3.10	3.10								34,-	43,-
139178	29.5-3.15	3.15								34,-	43,-



✚ Ventilværktøj
✚ Ventilverktyg

✚ Suzuki ventil værktøj
✚ Suzuki ventil verktyg

Passer til/passar till: GS 400/425/450/550/
750/850/1000/1100.



Varenr./art.nr. 192500
✚DKK ✚SEK
167,- 209,-

✚ Honda ventil værktøj
✚ Honda ventil verktyg

Passer til/passar till: CB 750 KZ/F - CB 900 F
- CBX 1000 - CB 1100 F.



Varenr./art.nr. 192501
✚DKK ✚SEK
167,- 209,-

✚ Yamaha ventil værktøj
✚ Yamaha ventil verktyg

Passer til/passar till: XJ 650/750/900.
XS 750/850/1100.



Varenr./art.nr. 192502
✚DKK ✚SEK
179,- 224,-

✚ Yamaha ventil værktøj
✚ Yamaha ventil verktyg

Passer til/passar till: FJ 1100/1200.
XJR 1200/1300.



Varenr./art.nr. 192503
✚DKK ✚SEK
179,- 224,-

✚ Kawasaki ventil værktøj
✚ Kawasaki ventil verktyg

Passer til/passar till: KZ 900/1000/1000 ZIR/
1000 ST/1000 MK II/1100/1300.



Varenr./art.nr. 192504
✚DKK ✚SEK
224,- 280,-

✚ Søgerblade til ventiljustering

Til japanske motorcykler.
Tolerance 0,04-0,30 mm.

✚ Bladmått til ventiljustering

Till japanske motorcyklar.
Tolerans 0,04-0,30 mm.



Varenr./art.nr. 192005
✚DKK ✚SEK
124,- 155,-

✚ Søgerblade til ventiljustering

Søgerblade i de mest benyttede tykkelser. Leveres
i pakker med 6 stk. Alle forsynet med håndtag.

✚ Bladmått till ventiljustering

Bladmått i de vanligaste tjocklekarna. Alla med handtag.
Levereras i 6-pack.

Str.: .002-.003 inches.
Varenr./art.nr. 08-052 - 6 stk. **281,- 351,-**

Str.: .004-.005 inches.
Varenr./art.nr. 08-053 - 6 stk. **295,- 369,-**

Str.: .006-.008 inches.
Varenr./art.nr. 08-054 - 6 stk. **308,- 385,-**

SORTIMENT:
2 af hver som ovenstående.
Varenr./art.nr. 08-055 **308,- 385,-**



✚ Ventiljustering med stilleskruer

Forchromet, varmebehandlet stålsæt m/tre str. topnøgler med håndtag:
8, 9 og 10 mm, og til tre typer justerværktøj; kærvskruer, 3 mm firkant
og 4 mm firkant. Passer til stort set alle Honda og Suzuki motorcykler
og ATV'ere med skruejustering. Passer også til Yamaha SR185/250,
XT/TT 250, XS 400.

✚ Ventiljustering med ställskruvar

Set med nycklar till ventiljustering 8,9 och 10 mm med handtag, och till
tre typer av justering: vanlig skruv, 3 mm fyrkant, 4mm fyrkant.
Justeringsverktøget kan fritt kombineras med toppnycklarna, allt som
allt 9 olika kombinationer. Överst på justerverktøget har du graderingar
som gör att det går snabbare. Passar i stort sätt alla Honda och Suzuki
motorcyklar men också ATV med skruvjustering. Passar också Yamaha
SR185/250, XT/TT250, XS400. Verktøget är förkromat i värmebehandlat
stål.

Varenr./art.nr. 08-073
✚DKK ✚SEK
335,- 419,-



Stikord
Sökord
s. 2-5

Forhandlere
Aterforsaljare
s. 6-9

Tøj/hjelme
Klæder/
hjelmar
s. 11

Dæk
Däck
s. 83

Olie
Olja
s. 115

Kæde/
tandhjul
Kedjor/
drev
s. 145

Bremser
Broms
s. 187

Låse
Lås
s. 347

Batteri
Batterier
s. 355

Pakninger
Packningar
s. 377

**Motordele
Motordelar
s. 411**

Lejer
Lager
s. 435

Karburator
Förgasare
s. 467

El-dele/
Tænding
Elektriskt/
Tänding
s. 509

Blinklygter
Baglygter
Belysning
Baklygter
s. 611

Lyddæmper
Avgassystem
s. 651

Støddæmper
Støtdämpare
s. 681

Luft/
oliefilter
Luft/
oljefilter
s. 711

Kobling
Koppling
s. 769

Kabler
Wire
s. 803

Styr/greb
Styre/
handtag
s. 829

Spejle
og diverse
Speglar
och diverse
s. 867

Bøjer/
værktøj
Böcker/
verktyg
s. 893

 Ventiler
 Ventiler
 Made in Japan



Märke/ modell	Prod. årg.	Indsugningsventiler				Udstødningsventiler				OEM-nr.	DKK	SEK
		Varenr.	Ant.	Ref.nr.	OEM-nr.	Varenr.	Ant.	Ref.nr.	OEM-nr.			

Märke/ modell	Prod. årg.	Indsugningsventiler				Avgasventiler				OEM-nr.	DKK	SEK
		Art.nr.	Ant.	Ref.nr.	OEM-nr.	Art.nr.	Ant.	Ref.nr.	OEM-nr.			

HONDA

CD 50/Dax (70cc)	Alle	138012	1		14711-035-000	68,-	43,-	138062	1	GG-1036-EX	14721-036-000/010	74,-	93,-
CB 250 RS	Alle	138000	2	GG-1013-IN	14711-428-000	142,-	178,-	138050	2	GG-1013-EX	14721-471-000	230,-	288,-
CMX 250 Rebel	Alle		2	GG-1054-IN	14711-KC1-920				2	GG-1054-EX	14721-KC1-920		
NX 250	88->			GG-	14711-KW3-000					GG-	14721-KW3-000		
XL 250 S	Alle	138000		GG-1013-IN	14711-428-000	142,-	178,-	138050		GG-1013-EX	14721-428-000	230,-	288,-
CB 400 F	75-78	138015	4	GG-	14711-377-000	126,-	158,-	138064	4	GG-	14721-377-000	196,-	245,-
CB 400 T/N	79-83	138001	4	GG-1019-IN	14711-413-000	200,-	250,-	138051	2	GG-1019-EX	14721-413-000	343,-	429,-
CM 400 T	Alle	138001	4	GG-1019-IN	14711-413-000	200,-	250,-	138051	2	GG-1019-EX	14721-413-000	343,-	429,-
CB 450 K	Alle	138022			14711-283/292-000	257,-	321,-	138071	1		14721-292-000	347,-	434,-
CB 500/550 F/K	72-78	138002	4	EVG-109A	14711-107-020	173,-	216,-	138052	4		14721-323-005	178,-	223,-
CX 500 A/B/C/E, GL 500	79-82	138003	4	GG-1009-IN	14711-415-000	209,-	261,-	138053	4	GG-1009-EX	14721-415-000	324,-	405,-
CBX 550 F/II	Alle		8	GG-	14711-MA7-000				8	GG-	14721-MA7-000		
CB 450 N/DXK	Alle		4	GG-	14711-KK9-960				2	GG-	14721-KK9-960		
CB 500 R	95-98			GG-	14711-MT4-000					GG-	14721-MT4-000		
XL 500 S/R/XR 500	Alle	138004		GG-1008-IN	14711-429-000	209,-	261,-	138054		GG-1008-EX	14721-429-000	343,-	429,-
VF 500 F	Alle		8	GG-	14711-KE8-020				8	GG-	14721-KE8-005		
CB 600 F Hornet	02-04		8	GG-1035-IN	14711-MAL-600				8	GG-1035-EX	14721-MAL-600		
CBR 600	87-90		8	GG-1034-IN	14711-MN4-000				8	GG-1034-EX	14721-MN4-000		
CBR 600	91-94		8	GG-1035-IN	14711-MV9-670				8	GG-1035-EX	14721-MV9-670		
CBR 600	95-98		8	GG-1035-IN	14711-MAL-600				8	GG-1035-EX	14721-MAL-600		
CBR 600 F4	99-05	138018	8	GG-1036-IN		213,-	266,-	138067		GG-1036EX		291,-	495,-
XL 600 / XR 600	Alle	138011			14711-MG3-000	173,-	216,-	138061			14721-MG3-000	236,-	295,-
XL 600 Trans Alp	Alle		8	GG-	14711-MF5-000				8	GG-	14721-MR1-000		
VT 600 Shadow	Alle		8	GG-	14711-MV1-000				8	GG-	14721-MR1-000		
CB 650	79-83	138005	4	GG-1007-IN	14711-426-003/000	173,-	216,-	138055	4	GG-1007-EX	14721-426-003/000	291,-	364,-
CX 650	83->							138053	4	GG-1009-EX	14721-415-000	324,-	405,-
FX 650 Vigor	99->	138011	4		14711-MG3-000	173,-	216,-	138061	4		14721-MG3-000	236,-	295,-
GL 650 Silberwing	83->							138053	4	GG-1009-EX	14721-415-000	324,-	405,-
SLR 650	97-99	138011	4		14711-MG3-000	173,-	216,-	138061	4		14721-MG3-000	236,-	295,-
NTV 650 Revere													
J/K/L/M	88-91			GG-	14711-MR1-000					GG-	14721-MR1-000		
NTV 650 Revere													
P/S/T/V	92-96			GG-	14711-MV1-000					GG-	14721-MR1-000		
NX 650 Dominator	93->	138011	4		14711-MG3-000	173,-	216,-	138061	4		14721-MG3-000	236,-	295,-
CB 750 K0-K6/F1	69-78	138006	4	GG-1002-IN	14711-300-005/000	182,-	228,-	138056	4	GG-1002-EX	14721-300-005/000	311,-	389,-
CB 750 F2/K7	77-79	138021			14711-410-010	257,-	321,-	138070			14721-410-010	347,-	434,-
CB 750 KZ/F/FC/C	79-83	138007	8	GG-1003-IN	14711-422-000	134,-	168,-	138057	8	GG-1003-EX	14721-422-000	297,-	371,-
VF 750 F			8	GG-	14711-MB2-000				8	GG-	14721-MB2-000		
VF 750 S/C													
Magna/Sabre	82-83	138008		GG-1001-IN	14711-MB0-000	141,-	176,-	138058		GG-1001-EX	14721-MB0-000	251,-	314,-
VF 750 S/C	84-86			GG-	14711-MB2-000					GG-	14721-MB2-000		
VFR 750 F	86			GG-	14711-ML7-000					GG-	14721-ML7-000		
VFR 750 F	87			GG-	14711-ML7-690					GG-	14721-ML7-690		
VFR 750 F	88-89			GG-	14711-ML7-920					GG-	14721-ML7-920		
VFR 750 F Pro Arm	90-93			GG-	14711-MT4-000					GG-	14721-MT4-000		
VFR 750 F Pro Arm	94-97			GG-	14711-MT4-000					GG-	14721-MY3-000		
CBX 750	Alle		8	GG-	14711-MJ0-000				8	GG-	14721-MJ0-000		
CB 900/1100 F	79-83	138009	8	GG-1006-IN	14711-438-000	176,-	220,-	138059	8	GG-1006-EX	14721-438-000	230,-	288,-
CBR 900 RR	93-99		8	GG-1037-IN	14711-MW0-000				8	GG-1037-EX	14721-MG3-000		
CBR 900 RR	00-03	138017	8	GG-1038-IN		242,-	303,-	138066	8	GG-4051-EX		393,-	491,-
CBX 1000 F	79-82	138007	12	GG-1003-IN	14711-422-000	134,-	168,-	138057	12	GG-1003-EX	14721-422-000	297,-	371,-
VF 1000 F	Alle		8	GG-	14711-MB6-000				8	GG-	14721-MB6-000		
CBR 1000	87->		8	GG-	14711-MN5-000				8	GG-	14721-MN5-000		
GL 1000/1100	Alle	138010	4	GG-1005-IN	14711-371-000	182,-	228,-	138060	4	GG-1005-EX	14721-371-000	315,-	394,-
GL 1100 Aspenc./ Interstate	Alle	138013	4	GG-1012-IN	14711-MB9-000	213,-	266,-	138060	4	GG-1005-EX	14721-371-000	315,-	394,-
VTR 1000	97-98			GG-	14711-MBB-000					GG-	14721-MBB-000		
CBR 1100 XX	97-98		8	GG-	14711-MAT-000				8	GG-	14721-MAT-000		

KAWASAKI

KL 250 A3-5	80-82	138125			12004-1006			138174			12005-1005		
KLR 250 D	84-92	138102	4	GG-4018-IN	12004-1052/1119	188,-	235,-	138151	4	GG-4018-EX	12005-1052	308,-	385,-
KLX 250 B2	82-83	138125			12004-1006			138174			12005-1005		
Ninja 250 R	06-09			GG-4028-IN						GG-4028-EX			
Z 400 D3 2-cyl.		138120	2		12004-013E	154,-	193,-	138169	2		12005-006	124,-	155,-
Z 400 J	80-84	138100	4	GG-4009-IN	12004-1016	159,-	199,-	138150	4	GG-4009-EX	12005-1013	269,-	336,-
EN 500 Vulcan	90->	138102	4	GG-4018-IN	12004-1052/1119	188,-	235,-	138151	4	GG-4018-EX	12005-1052	308,-	385,-
KLE 500	92->	138102	4	GG-4018-IN	12004-1052/1119	188,-	235,-	138151	4	GG-4018-EX	12005-1052	308,-	385,-
ER-5	97-98	138101	4	GG-4035-IN	12004-1119	189,-	236,-	138151	4	GG-4018-EX	12005-1052	308,-	385,-
GPZ 500 S	93-97	138102	4	GG-4018-IN	12004-1052	188,-	235,-	138151	4	GG-4018-EX	12005-1052	308,-	385,-
GPZ 500 S	94-02	138101	4	GG-4035-IN	12004-1119	189,-	236,-	138151	4	GG-4018-EX	12005-1052	308,-	385,-
Z 550	81-83	138100	4	GG-4009-IN	12004-1016	159,-	199,-	138150	4	GG-4009-EX	12005-1013	269,-	336,-
ZR 550 Zephyr	91-98	138100	4	GG-4009-IN	12004-1016	159,-	199,-	138150	4	GG-4009-EX	12005-1013	269,-	336,-

DKK PRISEN ER FOR 1 STK. · SEK PRISER ÄR FÖR 1 STYCK.

Ventiler
Ventiler
Made in Japan



Mærke/ model	Prod. årg.	Indsugningsventiler Varenr. Ant. Ref.nr.	OEM-nr.	Udstødningsventiler					
Mærke/ modell	Prod. årg.	Indsugningsventiler Art.nr. Ant. Ref.nr.	OEM-nr.	DKK	SEK	Avgasventiler Art.nr. Ant. Ref.nr.	OEM-nr.	DKK	SEK
KAWASAKI									
GPZ 550 Uni Track	84-89	138100 4	GG-4009-IN 12004-1016	159,-	199,-	138150 4	GG-4009-EX 12005-1013	269,-	336,-
GT 550	83-89	138100 4	GG-4009-IN 12004-1016	159,-	199,-	138150 4	GG-4009-EX 12005-1013	269,-	336,-
Z 550 B/2TD	80-83	138100 4	GG-4009-IN 12004-1016	159,-	199,-	138150 4	GG-4009-EX 12005-1013	269,-	336,-
Z 550 GP	81-84	138100 4	GG-4009-IN 12004-1016	159,-	199,-	138150 4	GG-4009-EX 12005-1013	269,-	336,-
ZR 550 A	83>	138100 4	GG-4009-IN 12004-1016	159,-	199,-	138150 4	GG-4009-EX 12005-1013	269,-	336,-
GPZ 600 R	Alle	138103 8	GG-4023-IN 12004-1064/75	179,-	224,-	138152 8	GG-4023-EX 12005-1062	217,-	271,-
GPX 600	Alle	138103 8	GG-4023-IN 12004-1064/75	179,-	224,-	138152 8	GG-4023-EX 12005-1062	217,-	271,-
ZZR 600	91-92	138103 8	GG-4023-IN 12004-1064/75	179,-	224,-	138152 8	GG-4023-EX 12005-1062	217,-	271,-
ZZR 600/ZX 600	93-98		GG- 12004-1109			8	GG- 12005-1190		
ZX 6 R	95-02	138104 8	GG-4040-IN 12004-1120	195,-	244,-	138153 8	GG-4040-EX 12005-1214	280,-	350,-
ZX 6 R	97-05	138105 8	GG-4044-IN 12004-1125	314,-	393,-	138154 8	GG-4044-EX 12005-1226	615,-	769,-
ZX6RR/636	03-04	138123 8	GG-4051-IN	348,-	435,-	138172 8	GG-4051-EX	519,-	649,-
ZX 636	05-07		GG-4056-IN				GG-4056-EX		
Z 650 B/F2/SR	Alle	138106 4	GG-4008-IN 12004-1011/016	182,-	228,-	138155 4	GG-4008-EX 12005-008	268,-	335,-
KLE 650 Versys	09-10		GG-4057-IN				GG-4057-EX		
Z 650 F3/4	82-83	138107 4	GG-4007-IN 12004-1007	182,-	228,-	138156 4	GG-4007-EX 12005-1006	297,-	371,-
ER-6	06-10		GG-4057-IN				GG-4057-EX		
KL 650 Tengai	89-92	138117 4	GG-4015-IN 12004-1021	186,-	233,-				
KLR 650	87-03	138117 4	GG-4015-IN 12004-1021	186,-	233,-				
ZX 7 R	96-03	138108 8	GG-4045-IN 12004-1124	232,-	290,-	138157 8	GG-4045-EX 12005-1223	666,-	833,-
ZXR 750 R	89>	138109 8	GG-4029-IN 12004-1088	200,-	250,-	138158 8	GG-4029-EX 12005-1224	339,-	424,-
Z 750 B 2-cyl.	76-79	138121 2	GG-4002-IN 12004-014	227,-	284,-	138170 2	GG-4002-EX 12005-007	311,-	389,-
Z 750 E	80-85	138107 4	GG-4007-IN 12004-1007/1058	182,-	228,-	138156 4	GG-4007-EX 12005-1006	297,-	371,-
GT 750	82-85	138107 4	GG-4007-IN 12004-1007/1058	182,-	228,-	138156 4	GG-4007-EX 12005-1006	297,-	371,-
Z 750 GP/R1	82	138107 4	GG-4007-IN 12004-1007/1058	182,-	228,-	138156 4	GG-4007-EX 12005-1006	297,-	371,-
Z 750 L1-4	81-84	138107 4	GG-4007-IN 12004-1007/1058	182,-	228,-	138156 4	GG-4007-EX 12005-1006	297,-	371,-
Z 750 LTD	80-82	138107 4	GG-4007-IN 12004-1007/1058	182,-	228,-	138156 4	GG-4007-EX 12005-1006	297,-	371,-
ZX 750 Turbo	84-85	138107 4	GG-4007-IN 12004-1007/1058	182,-	228,-	138156 4	GG-4007-EX 12005-1006	297,-	371,-
ZXR 750	90	138107 4	GG-4007-IN 12004-1007/1058	182,-	228,-	138156 4	GG-4007-EX 12005-1006	297,-	371,-
GPX 750	87-90	138110 8	GG-4025-IN 12004-1069	188,-	235,-	138159 8	GG-4025-EX 12005-1077	234,-	293,-
GPZ 750 Uni Trak	80-85	138107 4	GG-4007-IN 12004-1007	182,-	228,-	138156 4	GG-4007-EX 12005-1006	297,-	371,-
ZR 750 (Zephyr 750)	91-97	138107 4	GG-4007-IN 12004-1007/1058	182,-	228,-	138156 4	GG-4007-EX 12005-1006	297,-	371,-
ZR 750 / Z 750 S	06-07		GG-4054-IN				GG-4054-EX		
VN 800 Vulcan/Drifter	95-05	138111 2	GG-4041-IN 12004-1121	335,-	419,-	138160 2	GG-4041-EX 12005-1225	587,-	734,-
Z1 / Z 900	73-76	138112 4	GG-4001-IN 12004-012	270,-	338,-	138161 4	GG-4001-EX 12005-005	351,-	439,-
ZX 9 R	94-97	138113 8	GG-4037-IN 12004-1112	200,-	250,-	138162 8	GG-4037-EX 12005-1198	301,-	376,-
ZX 9 R	98-03	138122 8	GG-4046-IN 12004-1132	345,-	431,-	138171 8	GG-4046-EX 12005-1256	452,-	565,-
GPZ 900 R	84-93	138102 8	GG-4018-IN 12004-1052/62/63/66	188,-	235,-	138151 8	GG-4018-EX 12005-1052/65	308,-	385,-
VN 900	06-10	138111 2	GG-4041-IN 12004-1121	335,-	419,-	138160 2	GG-4041-EX 12005-1225	587,-	734,-
GTR 1000	84-93	138102 8	GG-4018-IN 12004-1052/62/63/66	188,-	235,-	138151 8	GG-4018-EX 12005-1052/65	308,-	385,-
GTR 1000	06	138102 8	GG-4018-IN 12004-1052/62/63/66	188,-	235,-	138151 8	GG-4018-EX 12005-1052/65	308,-	385,-
GPZ 1000 RX	86-87	138102 8	GG-4018-IN 12004-1052/62/63/66	188,-	235,-	138151 8	GG-4018-EX 12005-1052/65	308,-	385,-
Z 1000 A1	77-80	138114 4	GG-4003-IN 12004-017/1010	261,-	326,-	138163 4	GG-4003-EX 12005-009/1009	315,-	394,-
Z1 R/MKII/ST	77-80	138114 4	GG-4003-IN 12004-017/1010	261,-	326,-	138163 4	GG-4003-EX 12005-009/1009	315,-	394,-
Z 1000 J	81-83	138115 4	GG-4005-IN 12004-1013	166,-	208,-	138164 4	GG-4005-EX 12005-1011	268,-	335,-
Z 1000 R	82-83	138115 4	GG-4005-IN 12004-1013	166,-	208,-	138164 4	GG-4005-EX 12005-1011	268,-	335,-
ZX 10	88-91	138116 8	GG-4027-IN 12004-1083	225,-	281,-	138165 8	GG-4027-EX 12005-1107	377,-	471,-
ZL 1000 Eliminator	87>	138102 4	GG-4018-IN 12004-1052/1119	188,-	235,-	138151 4	GG-4018-EX 12005-1052	308,-	385,-
Z1000/ZR 1000 C	03-05	138122 8	GG-4046-IN 12004-1132	345,-	431,-	138171 8	GG-4046-EX 12005-1256	452,-	565,-
GPZ 1100	81-83	138115 4	GG-4005-IN 12004-1013	166,-	208,-	138164 4	GG-4005-EX 12005-1011	268,-	335,-
GPZ 1100 Horizon	95-97	138118 8	GG-4031-IN 12004-1093	225,-	281,-	138168 8	GG-4031-EX 12005-1148	452,-	565,-
GPZ 1100 Uni Trak	81-85	138117 4	GG-4015-IN 12004-1021	186,-	233,-	138167 4	GG-4015-EX 12005-1016	295,-	369,-
ZR 1100 (Zephyr 1100)	06		GG-4042-IN				GG-4042-EX		
Z 1100 GP/ST	81-83	138115 4	GG-4005-IN 12004-1013	166,-	208,-	138164 4	GG-4005-EX 12005-1011	268,-	335,-
ZZR 1100	90-92	138118 8	GG-4031-IN 12004-1093	225,-	281,-	138168 8	GG-4031-EX 12005-1148	452,-	565,-
ZZR 1100	93-01	138119 8	GG-4039-IN 12004-1115	191,-	239,-	138168 8	GG-4031-EX 12005-1148	452,-	565,-
GPZ 1100 E1/E2	95-97	138119 8	GG-4039-IN 12004-1115	191,-	239,-	138168 8	GG-4031-EX 12005-1148	452,-	565,-
ZXR 1100	97-99	138118 8	GG-4031-IN 12004-1093	225,-	281,-	138168 8	GG-4031-EX 12005-1148	452,-	565,-
ZR 1100 C3/C4	99-00	138119 8	GG-4039-IN 12004-1115	191,-	239,-	138168 8	GG-4031-EX 12005-1148	452,-	565,-
ZRX 1200	01-05	138119 8	GG-4039-IN 12004-1115	191,-	239,-	138168 8	GG-4031-EX 12005-1148	452,-	565,-
ZZR 1200	02-05	138119 8	GG-4039-IN 12004-1115	191,-	239,-	138168 8	GG-4031-EX 12005-1148	452,-	565,-
Z 1300	79-83	138127	12004-1004			138176	12005-1004		
Z 1300 DFI	84-89	138128	12004-1020	320,-	400,-	138177	12005-1063	418,-	523,-
VN 1500	06-08		GG-4024-IN				GG-4024-EX		
VN 1600	05-08		GG-4024-IN				GG-4024-EX		

SUZUKI

GN 250	Alle	138200 2	GG-3013-IN 12911-38200	169,-	211,-	138250 2	GG-3018-EX 12912-38200	268,-	335,-
GSX 250 8 ventil	80-81	138227 4	GG-3005-IN 12911-11400	154,-	193,-	138251 4	GG-3005-EX 12912-11400	220,-	275,-
GSX R 250	90>		GG- 12911-05C03			8	GG- 12912-05C01		
TU 250 XV	97-98	138200 2	GG-3013-IN 12911-38200	169,-	211,-	138250 2	GG-3013-EX 12912-38200	268,-	335,-
GT 250 Marauder	99-10	138200 2	GG-3013-IN 12911-38200	169,-	211,-	138250 2	GG-3013-EX 12912-38200	268,-	335,-
DR 350	Alle	138201 1	GG-3028-IN 12911-14D01	159,-	199,-	138252 1	GG-3028-EX 12912-14D01	385,-	481,-

✚ PRISEN ER FOR 1 STK. ✚ PRISER ÅR FÖR 1 STYCK.

- Stikord Sökord s. 2-5
- Forhandlere Aterforsäljare s. 6-9
- Tøj/hjelme Klæder/hjälmar s. 11
- Dæk Däck s. 83
- Olje Olja s. 115
- Kæde/tandhjul Kedjor/drev s. 145
- Bremser Broms s. 187
- Låse Lås s. 347
- Batteri Batterier s. 355
- Pakninger Packningar s. 377
- Motordele Motordele s. 411
- Lejer Lager s. 435
- Karburator Förgasare s. 467
- El-dele/Tænding Elektriskt/Tænding s. 509
- Blinklygter Baglygter Belysning Baklygter s. 611
- Lyddæmper Avgassystem s. 651
- Støddæmper Støtdåmpare s. 681
- Luft/oliefilter Luft-/oljefilter s. 711
- Kobling Koppling s. 769
- Kabler Wire s. 803
- Styr/greb Styre/handtag s. 829
- Spejle og diverse Speglar och diverse s. 867
- Bøger/værktøj Båker/verktyg s. 893

 Ventiler
 Ventiler
 Made in Japan





Märke/ modell	Prod. årg.	Indsugningsventiler			OEM-nr.	Udstødningsventiler			
		Varenr.	Ant.	Ref.nr.		Varenr.	Ant.	Ref.nr.	OEM-nr.
Märke/ modell	Prod. årg.	Indsugningsventiler			OEM-nr.	Avgasventiler			
		Art.nr.	Ant.	Ref.nr.		Art.nr.	Ant.	Ref.nr.	OEM-nr.

SUZUKI

GSX 400, 8 ventil	80-84	138220	4	GG-3005-IN	12911-11400	209,-	261,-	138251	4	GG-3005-EX	12912-11400	220,-	275,-
GS 400/425	77-79	138203	2	GG-3002-IN	12911-45011	154,-	193,-	138253	2	GG-3002-EX	12912-45011	269,-	336,-
GSX 400, 2-cyl.	80-83	138204	4	GG-3001-IN	12911-45410	144,-	180,-	138254	4	GG-3001-EX	12912-45410	229,-	286,-
GSX R 400 J	88->	138205	8	GG-3025-IN	12911-32C01	191,-	239,-	138255	8	GG-3025-EX	12912-32C02	343,-	429,-
GSF 400 Bandit	92->	138205	8	GG-3025-IN	12911-32C01	191,-	239,-	138255	8	GG-3025-EX	12912-32C02	343,-	429,-
GS 450	80-87	138203	2	GG-3002-IN	12911-45011	154,-	193,-	138253	2	GG-3002-EX	12912-45011	269,-	336,-
GS 500 E	89-06	138206	2	GG-3024-IN	12911-01D01	224,-	280,-	138256	2	GG-3024-EX	12912-01D00	377,-	471,-
GS 500 F	04-09	138206	2	GG-3024-IN	12911-01D01	224,-	280,-	138256	2	GG-3024-EX	12912-01D00	377,-	471,-
GSX 550 E	83-87		8	GG-	12911-43400				8	GG-	12912-43400		
GS 550 E	77-83	138207	4	GG-3006-IN	12911-34200/47011	141,-	176,-	138257	4	GG-3006-EX	12912-34203/47011	208,-	260,-
GSF 600 Bandit	95-03	138208	8	GG-3023-IN	12911-19C00	249,-	311,-	138258	8	GG-3023-EX	12912-19C00	375,-	469,-
GSX 600 F	90-98	138209	8	GG-3034-IN	12911-19E00	212,-	265,-	138259	8	GG-3034-EX	12912-19E00	312,-	390,-
GSX 600 F	98-05	138228	8	GG-3023-IN	12911-19C00	251,-	314,-	138276	8	GG-3023-EX	12912-19C00	377,-	471,-
GSX R 600	97-00	138210	8	GG-3040-IN	12911-34E00	280,-	350,-	138260	8	GG-3040-EX	12912-34E00	421,-	526,-
GSX R 600	01-03	138230	8	GG-3046-IN		212,-	265,-	138278	8	GG-3046-EX		280,-	350,-
RF 600	94-97	138211	8	GG-3029-IN	12911-18E00	251,-	314,-	138261	8	GG-3029-EX	12912-18E00	363,-	454,-
GS 650 E/Katana	81-83	138207	4	GG-3006-IN	12911-34200/47011	141,-	176,-	138257	4	GG-3006-EX	12912-34203/47011	208,-	260,-
LS 650	>95	138212	1	GG-3030-IN	12911-02C00	269,-	336,-	138262	1	GG-3030-EX	12912-02C00	404,-	505,-
LS 650	95-10	138213	1	GG-3031-IN	12911-24B01	251,-	314,-	138263	1	GG-3031-EX	12912-24B01	363,-	454,-
XF 650 V	97-98		2	GG-	12911-04F00				2	GG-	12912-04F00		
SV 650 X/Y/S	99-10	138225	4	GG-3036-IN	12911-46E00	270,-	338,-	138274	4	GG-3042-EX	12912-20F00	370,-	463,-
SFV 650 Gladius	10	138225	4	GG-3036-IN	12911-46E00	270,-	338,-	138274	4	GG-3042-EX	12912-20F00	370,-	463,-
DL 650 V-Strom	04-10	138225	4	GG-3036-IN	12911-46E00	270,-	338,-	138274	4	GG-3042-EX	12912-20F00	370,-	463,-
GS 750	77-84	138203	4	GG-3002-IN	12911-45011	154,-	193,-	138253	4	GG-3002-EX	12912-45011	269,-	336,-
GSX 750 T/ET/X/EX	80-83	138204	8	GG-3001-IN	12911-45410/20	144,-	180,-	138254	8	GG-3001-EX	12912-45410/20	229,-	286,-
GSX 750 ESD/ES	84-87	138214	8	GG-3015-IN	12911-31300	188,-	235,-	138264	8	GG-3015-EX	12912-31301	247,-	309,-
GSX R 750	86-87	138215	8	GG-3019-IN	12911-27A03	166,-	208,-	138265	8	GG-3019-EX	12912-27A01	222,-	278,-
GSX 750 FL	89-97	138216	8	GG-3022-IN	12911-17002	242,-	303,-	138266	8	GG-3022-EX	12912-17C00	377,-	471,-
GSX 750 F	98-08	138231		GG-3048-IN		345,-	431,-	138279		GG-3048-EX		501,-	626,-
GSX-R 750	00-03	138229	8	GG-3045-IN	12911-	312,-	390,-	138277	8	GG-3045-EX	12912-	443,-	554,-
GSX R 750 T	96-99	138217	8	GG-3038-IN	12911-33E00	251,-	314,-	138267	8	GG-3027-EX	12912-17E00/1	348,-	435,-
GSX R 750	93-95	138218	8	GG-3027-IN	12911-17E00	229,-	286,-	138267	8	GG-3027-EX	12912-17E00/1	348,-	435,-
GSX R 750	88-89	138216	8	GG-3022-IN	12911-17C02	242,-	303,-	138266	8	GG-3022-EX	12912-17C00	377,-	471,-
VS/VX 800	Alle		4	GG-	12911-38A02				4	GG-	12912-38A02		
VZ 800 Marauder	97-98		4	GG-	12911-38A02				4	GG-	12912-38A02		
GS 850 G	78-84	138203	2	GG-3002-IN	12911-45011	154,-	193,-	138253	2	GG-3002-EX	12912-45011	269,-	336,-
RF 900	Alle	138219	8	GG-3035-IN	12911-31E00	267,-	334,-	138267	8	GG-3027-EX	12912-17E00/1	348,-	435,-
GSX-R 1000	00-04	138229	8	GG-3045-IN	12911-	312,-	390,-	138277	8	GG-3045-EX	12912-	443,-	554,-
GS 1000	78->	138220	4	GG-3007-IN	12911-49020	209,-	261,-	138268	4	GG-3007-EX	12912-49020	242,-	303,-
TL 1000 S/R	97-03	138221	4	GG-3041-IN	12911-02F00	288,-	360,-	138269	4	GG-3041-EX	12912-02F00	427,-	534,-
DL 1000 V-Strom	02-10		4	GG-3051-IN				138269	4	GG-3041-EX	12912-02F00	427,-	534,-
DL 1000 V-Strom	03-05							138269	4	GG-3041-EX	12912-02F00	427,-	534,-
SV 1000 /S	03-06							138269	4	GG-3041-EX	12912-02F00	427,-	534,-
GSX 1100 FJ	89->	138222	8	GG-3018-IN	12911-06B02	191,-	239,-	138270	8	GG-3018-EX	12912-06B00	249,-	311,-
GSX 1100 / Katana	81->	138223	8	GG-3008-IN	12911-49220	166,-	208,-	138271	8	GG-3008-EX	12912-49220	250,-	313,-
GSX 1100 EF	85->		8	GG-	12911-00A00				8	GG-	12912-49220		
GSX R 1100	86-90	138222	8	GG-3018-IN	12911-06B02	191,-	239,-	138270	8	GG-3018-EX	12912-06B00	249,-	311,-
GSX R 1100	91-92	138224	8	GG-3032-IN	12911-41C00	251,-	314,-	138272	8	GG-3032-EX	12912-41C00	363,-	454,-
GSX R 1100	93-98	138225	8	GG-3036-IN	12911-46E00	270,-	338,-	138273	8	GG-3036-EX	12912-46E00	360,-	450,-
GSF 1200 Bandit	97-03	138222	8	GG-3018-IN	12911-06B02	191,-	239,-	138270	8	GG-3018-EX	12912-06B00	249,-	311,-
GSF 1250 Bandit	07-10	138225	4	GG-3036-IN	12911-46E00	270,-	338,-	138274	4	GG-3042-EX	12912-20F00	370,-	463,-
GSX 1300 RX													
Hayabusa	99-07	138226	8	GG-3043-IN	12911-24F00	411,-	514,-	138275	8	GG-3043-EX	12912-24F00	597,-	746,-

YAMAHA

XV 250	94-02	138300	2	GG-2022-IN	50M-12111-00	209,-	261,-	138350	2	GG-2022-EX	50M-12121-01	345,-	431,-
XT 250	80-90	138301	1	GG-2006-IN	3Y1-12111-00	196,-	245,-	138351	1	GG-2006-EX	3Y1-12121-00	297,-	371,-
SR 250	80-82	138301	1	GG-2006-IN	3Y1-12111-00	196,-	245,-	138351	1	GG-2006-EX	3Y1-12121-00	297,-	371,-
SR 250 Classic	97-98	138301	1	GG-2006-IN	3Y1-12111-00	196,-	245,-	138351	1	GG-2006-EX	3Y1-12121-00	297,-	371,-
XT 350	85->	138312	1	GG-	30X-12111-01	134,-	168,-	138362	1	GG-	30X-12121-00	169,-	211,-
XS 360 / 400	Alle	138302	2	GG-2008-IN	1L9-12111-03	236,-	295,-	138352	2	GG-2008-EX	1L9-12121-02	268,-	335,-
XS 400 Seca	Alle	138303	2	GG-2001-IN	1J7-12111-00	209,-	261,-	138353	2	GG-2001-EX	1J7-12121-00	236,-	295,-
XT / SR 500	78-93	138304	1	GG-2007-IN	583-12111-00	257,-	321,-	138354	1	GG-2007-EX	583-12121-00	330,-	413,-
XT 500	80->	138310	2	GG-2011-IN	2J2-12111-00	229,-	286,-	138354	1	GG-2007-EX	583-12121-00	330,-	413,-
XV 535	Alle		2	GG-	22U-12111-000				2	GG-	22U-12121-01		
XT 550	Alle	138305	1	GG-2017-IN	5Y1-12111-00	203,-	254,-	138355	1	GG-2017-EX	5Y1-12121-00	304,-	380,-
XZ 550	Alle	138306	2	GG-2010-IN	11H-12111-00	200,-	250,-	138356	2	GG-2010-EX	4U8-12121-00	213,-	266,-
XJ 550	81-84	138326			4UB-12111-00			138371			4U0-12121-00		
XT 600	Alle	138313	2	GG-2023-IN	1VJ-12111-00	280,-	350,-	138363	2	GG-2023-EX	1VJ-12121-00	328,-	410,-
FZR 600	89-96		8	GG-	4JH-12111-00				8	GG-	4JH-12121-01		
XJ 600	84-93		4	GG-	49A-12111-00				4	GG-	49A-12121-00		
XJ 600 Diversion	Alle		4	GG-	4BR-12111-00				4	GG-	4BR-12121-00		
YZF 600 R	96-98		8	GG-					8	GG-	4TV-12121-01		

✚ PRISER ER FOR 1 STK. ✚ PRISER ÄR FÖR 1 STYCK.

Ventiler
Ventiler
Made in Japan



Mærke/ model	Prod. årg.	Indsugningsventiler			OEM-nr.	Udstødningsventiler				OEM-nr.			
		Varenr.	Ant.	Ref.nr.		Varenr.	Ant.	Ref.nr.	OEM-nr.				
Mærke/ modell	Prod. årg.	Indsugningsventiler Art.nr.	Ant.	Ref.nr.	OEM-nr.	DKK	SEK	Avgasventiler Art.nr.	Ant.	Ref.nr.	OEM-nr.	DKK	SEK
YAMAHA													
YZF 600 R6	99-02	138319	8	GG-2026-IN	5EB-12111-00	212,-	265,-	138267	8	GG-2026-EX	5EB-12121-00	348,-	589,-
XVS 650 Drag Star	97-98		4	GG-	4VR-12111-00				4	GG-	4VR-12121-00		
XS 650	Alle	138307	2	GG-2005-IN	341-12111-03	270,-	338,-						
XJ 650	80-84	138308	4	GG-2004-IN	4H7-12111-00	134,-	168,-	138358	4	GG-2004-EX	4H7-12121-00	263,-	329,-
XJ 650 Turbo	82	138308	4	GG-2004-IN	4H7-12111-00	134,-	168,-	138358	4	GG-2004-EX	4H7-12121-00	263,-	329,-
XT 660 R/X		138327			5VK-12111-00			138372			5VK-12121-00		
XTZ 660 F/R		138328			3YF-12111-00			138373			3YF-12121-00		
XJ 750 Seca	82>	138308	4	GG-2004-IN	4H7-12111-00	134,-	168,-	138358	4	GG-2004-EX	4H7-12121-00	263,-	329,-
XV 750 Virago	81-98	138309	2	GG-2003-IN	4X7-12111-00	238,-	298,-						
FZ/FZR 750	Alle		8	GG-	1AA-12112-01				8	GG-	1AA-12121-01		
FZ/FZR 750	Alle		4	GG-	1AA-12111-01								
YZF 750	93-98		4	GG-	4FM-12111-00				8	GG-	4FM-12121-00		
YZF 750	93-98		8	GG-	4FM-12112-00								
XS 750/850	78-81	138303	3	GG-2001-IN	1J7-12111-00	209,-	261,-	138353	3	GG-2001-EX	1J7-12121-00	236,-	295,-
TDM/TRX 850	Alle		2	GG-	3LD-12111-00				4	GG-	32D-12121-00		
TDM/TRX 850	Alle		4	GG-	3LD-12112-00								
XV 920/1000/TR1	81-86	138310	2	GG-2011-IN	2J2-12111-00	229,-	286,-	138360	2	GG-2011-EX	5A8-12121-00	314,-	393,-
XJ 900	Alle		4	GG-	31A-12111-00				4	GG-	31A-12121-00		
XJ 900 Diversion	96-98		4	GG-	4KM-12111-00				4	GG-	4KM-12121-00		
FZR 1000 Genesis	87-88		8	GG-	2GH-12112-00				8	GG-	2GH-12121-00		
FZR 1000 Genesis	87-88		4	GG-	2GH-12111-00								
FZR 1000 Exup	89>	138314	4	GG-	3GM-12111-00	159,-	199,-		8	GG-	3GM-12121-00		
FZR 1000 Exup	89>	138315	8	GG-	3GM-12112-00	124,-	155,-						
GTS 1000	Alle	138314	4	GG-	3GM-12111-00	159,-	199,-		8	GG-	3GM-12121-00		
GTS 1000	Alle	138315	8	GG-	3GM-12112-00	124,-	155,-						
YZF 1000	96-98	138314	4	GG-	3GM-12111-00	159,-	199,-	138364	8	GG-	4SV-12121-00	196,-	245,-
YZF 1000	96-98	138315	8	GG-	3GM-12112-00	124,-	155,-						
YZF 1000 R1	99-04	138320	4	GG-2027-IN	4XV-12111-00	179,-	224,-	138368	8	GG-2027-EX	4XV-12121-00	471,-	589,-
YZF 1000 R1	99-04	138321	8	GG-2029-IN	4XV-12112-00	199,-	249,-						
FZ 1	04-06	138321	8	GG-2029-IN	4XV-12112-00	199,-	249,-						
FZ 1	04-06	138320	4	GG-2027-IN	4XV-12111-00	179,-	224,-	138368	4	GG-2027-EX	4XV-12121-00	471,-	589,-
XS 1100/S	78-81	138303	4	GG-2001-IN	1J7-12111-00	209,-	261,-	138353	4	GG-2001-EX	1J7-12121-00	236,-	295,-
XV 1100 Virago	88-99	138310	2	GG-2011-IN	2J2-12111-00	229,-	286,-	138360	2	GG-2011-EX	5A8-12121-00	314,-	393,-
XVS 1100 Drag Star	99-10	138310	2	GG-2011-IN	2J2-12111-00	229,-	286,-	138360	2	GG-2011-EX	5A8-12121-00	314,-	393,-
FJ 1100/1200	84>	138316	8	GG-	36Y-12111-00	186,-	233,-	138365	8	GG-	36Y-12121-00	365,-	456,-
V-MAX	85-07	138311	8	GG-2019-IN	1FK-12111-00	166,-	208,-	138361	8	GG-2019-EX	1FK-12121-01	328,-	410,-

DKK PRISEN ER FOR 1 STK. · SEK PRISET ÄR FÖR 1 STYCK.

Stikord
Sökord
s. 2-5

Forhandlere
Aterforsaljare
s. 6-9

Tøj/hjelme
Klæder/
hjelmar
s. 11

Dæk
Dæk
s. 83

Olje
Olja
s. 115

Kæde/
tandhjul
Kedjor/
drev
s. 145

Bremser
Broms
s. 187

Låse
Lås
s. 347

Batteri
Batterier
s. 355

Pakninger
Packningar
s. 377

Motordele
Motordele
s. 411

Lejer
Lager
s. 435

Karburator
Förgasare
s. 467

El-dele/
Tænding
Elektriskt/
Tænding
s. 509

Blinklygter
Baglygter
Belysning
Baklygter
s. 611

Lyddæmper
Avgassystem
s. 651

Støddæmper
Støtdåmpare
s. 681

Luft/
oliefilter
Luft/
oljefilter
s. 711

Kobling
Koppling
s. 769

Kabler
Wire
s. 803

Styr/greb
Styre/
handtag
s. 829

Spejle
og diverse
Speglar
och diverse
s. 867

Bøjer/
værktøj
Böcker/
verktyg
s. 893



🇩🇰 Japanske topkvalitets knastkæder

100 % et OEM produkt

Knastkæder fra japanske Tourmax er oprindeligt udviklet i USA, men japanerne har forenklet og gjort kæderne til noget nær det perfekte. Knastkæderne er verdens mest lydsvage! Husk at kæderne ofte skal kortes af, sammenlign derfor modelskemaet med referencelisten. **VIGTIGT! Skal kæden afkortes, anbefales det at bruge professionelt nitteværktøj med varenr.**

08-058

🇸🇪 Japanska top kvalitets kamkedjor

100 % et OEM produkt

Kamkedjor från Japanska Tourmax är beprövad och utvecklad i USA, men japanerna har förenklat och utvecklat samt gjort kedjorna ännu bättre. Kamkedjorna är en av världens mest slits-tarka! Observera att kedjorna ofta skall kortas av, kolla därför först i den samlade referenslistan för just din modell.

VIKTIGT! Skall kedjan kortas rekommenderas du att använda ett professionellt nitverktyg art.nr.

08-058

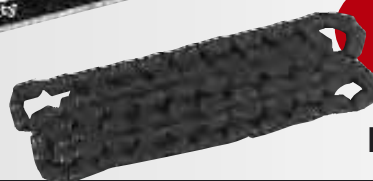

Made in Japan

Mærke/ model	Årg.	Varenr.	Antal led	OEM-nr.	Tourmax-nr.	DID-nr.	Borgwerna-nr.		
Märke/ modell	Årg.	Art.nr.	Antal länk.	OEM-nr.	Tourmax-nr.	DID-nr.	Borgwerna-nr.	DKK	SEK
APRILIA									
NY Leonardo 125	95-96		96				82RH2005		
NY Scarabeo 125	00-02		96		CCM-Y	—	92RH2005		
NY Leonardo 150	97		96				82RH2005		
NY Scarabeo 150	00-02		96		CCM-Y	—	92RH2005		
NY Atlantic 200	04		96		CCM-Y	—	92RH2005		
NY Scarabeo 200	00-03		96		CCM-Y	—	92RH2005		
NY Scarabeo 200 GT	04		96		CCM-Y	—	92RH2005		
NY Sportcity 200	04-05		96		CCM-Y	—	92RH2005		
NY Leonardo 250 ST	04		104				82RH2005		
NY Leonardo 300 ST	05		104				82RH2005		
NY Atlantic 500	02-04		106		CCM-J	SCR0409SDH	92RH2010	695,-	869:-
NY Scarabeo 500	04		106		CCM-J	SCR0409SDH	92RH2010	695,-	869:-
NY ETX 600 Tuareg	86	055048	132		CCM-A	SCA0412ASDH	82RH2015	695,-	869:-
NY Pegaso 2	93-96	055048	132		CCM-A	SCA0412ASDH	82RH2015	695,-	869:-
NY Pegaso 3	97-02	055048	132		CCM-A	SCA0412ASDH	82RH2015	695,-	869:-
NY Pegaso 600	90-91	055048	132		CCM-A	SCA0412ASDH	82RH2015	695,-	869:-
NY Rally 600	86-87	055048	132		CCM-A	SCA0412ASDH	82RH2015	695,-	869:-
NY Wind 600	86-91	055048	132		CCM-A	SCA0412ASDH	82RH2015	695,-	869:-
NY Moto 6,5	95-99	055048	132		CCM-A	SCA0412ASDH	82RH2015	695,-	869:-
NY Pegaso 650	91-01	055048	132		CCM-A	SCA0412ASDH	82RH2015	695,-	869:-
NY Pegaso 650	92	055048	132		CCM-A	SCA0412ASDH	82RH2015	695,-	869:-
NY DORSODURO - SHIVER 750cc	07>	055077	112		CCM-E	SCR0412SDH	92RH2015	558,-	698:-
NY RSV4R 1000cc	Alle	055085	124		CCM-FF	—	98XRH2010	465,-	581:-
NY RSV4 FACTORY 1000cc	Alle		124				98XRH2015		
NY DORSODURO - SHIVER 1200cc	10		52		CCM-Y	—	92RH2005		
NY DORSODURO - SHIVER 1200cc	10	055077	114		CCM-E	SCR0412SDH	92RH2015	558,-	698:-
BMW									
NY G 450 X	Alle		122		CCM-E	SCR0412SDH	92RH2015		
NY F800R / F800GS / F800S / F800ST	Alle		146				98RXH2015		
NY S 1000 RR	Alle		108				98RXH2015		
NY K 1200 LT	06>		126				98RXH2015		
NY K 1200 R	06>		126				98RXH2015		
NY K 1300GT	06>		126				98RXH2015		
NY K 1300 R	06>		126				98RXH2015		
NY K 1300 S	06>		126				98RXH2015		
BUELL									
NY 1125 CR-R	Alle		144		CCM-Z		98XRH2020		
CAGIVA									
NY Canyon 600	96-98	055045	122		CCM-A	SCA0412ASDH	82RH2015	645,-	806:-
NY River 600	95-97	055045	122		CCM-A	SCA0412ASDH	82RH2015	645,-	806:-
NY W16 600	93-97	055045	122		CCM-A	SCA0412ASDH	82RH2015	645,-	806:-
NY Raptor 1000	00-03	055069	92		CCM-E	SCR0412SDH	92RH2015	425,-	531:-
DAELIM									
NY NF 100			96				82RH2005		
NY SL 125			90		CCM-Y	—	92RH2005		
NY VL 125			98				82RH2005		
NY VX 125, VC125			100				82RH2005		
GILERA									
NY Runner 200	04		96		CCM-Y	—	92RH2005		
NY Nexus 500	04	055074	106		CCM-J	SCR0409SDH	92RH2010	560,-	700:-

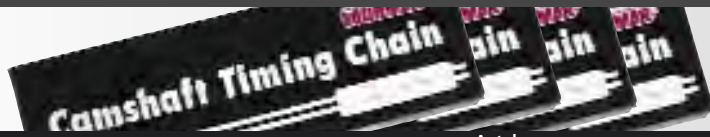

Made in Japan

Märke/ modell	Årg.	Varenr.	Antal led	OEM-nr.	Tourmax-nr.	DID-nr.	Borgvarna-nr.		
Märke/ modell	Årg.	Art.nr.	Antal länk.	OEM-nr.	Tourmax-nr.	DID-nr.	Borgvarna-nr.	DKK	SEK
HONDA									
CB 72-250 cc/CB 77 350 cc	61-66	055003	94			219T		255,-	319,-
CB 250/350T	68-74	055003	94			219T		255,-	319,-
CB 250 RS	80-84	055037	104	14401-428-003	CMM-A	SCA0412ASDH	82RH2015	510,-	638,-
CB 250 T	75-78	055003	94			219T		255,-	319,-
CMX 250 Rebel	93-09	055040	98		CMM-A	SCA0412ASDH	82RH2015	585,-	731,-
XL 250	73-76	055003	94			219T		255,-	319,-
XL 250 K3/K4	78-90	055003	94	14401-286-003		219T		255,-	319,-
XL 250 K3/K4	84-87	055037	102	14401-KK1-003	CCM-A	SCA0412ASDH	82RH2015	510,-	638,-
XL 250 S/SZ/A/SB/RC	78-83	055037	104	14401-428-003	CCM-A	SCA0412ASDH	82RH2015	510,-	638,-
XR 250 RE-RS	84-95	055037	102	14401-KK1-003	CCM-A	SCA0412ASDH	82RH2015	510,-	638,-
XR 250 R	96-04	055024	102		CMM-B	SCA0409ASDH	82RH2010	510,-	638,-
CRF 250 X	04-07	055072	104		CMM-E	SCR0412SDH	92RH2015	588,-	735,-
CB 350 F	73-75	055001	82	14401-333-003		219T		218,-	273,-
XL 350	83-87	055037	108	14401-414-004	CMM-A	SCA0412ASDH	82RH2015	510,-	638,-
CB 350 G	75	055003	92	14401-369-003		219T		255,-	319,-
CJ 360 T	78	055003	92	14401-369-003		219T		255,-	319,-
CB 400 N/NA/NB	78/85	055037	110	14401-413-014	CCM-A	SCA0412ASDH	82RH2015	510,-	638,-
CB 400 T	78-80	055037	110	14401-413-014	CCM-A	SCA0412ASDH	82RH2015	510,-	638,-
CB 400 F	75-79	055001	82	14401-333-003		219T		218,-	273,-
CBX 400 F	82-85	055048	130	14401-MA7-000	CMM-A	SCA0412ASDH	82RH2015	695,-	869,-
VF 400 F	83-86	055013	106	14401-KE8-003	CMM-G	219FTSSDHA	BF05M	338,-	423,-
XR 400	96-04	055024	112	14401-	CMM-B	SCA0409ASDH	82RH2010	510,-	638,-
CB 450 Twin	65-76	055006	128	14401-283-000		219T		326,-	408,-
CB 450 DX	89>	055037	110	14401-413-014	CCM-A	SCA0412ASDH	82RH2015	510,-	638,-
CB 450 S	86-89	055040	110	14401-413-004	CCM-A	SCA0412ASDH	82RH2015	585,-	731,-
CMX 450 C Rebell (PC17)	86->	055037		14401-413-014	CCM-A	SCA0412ASDH	82RH2015	510,-	638,-
CB 500 K1/K2/K3/F	75-78	055001	88	14401-323/362-003		219T		218,-	273,-
CB 500 Twin	75-78	055006	128	14401-283-000		219T		326,-	408,-
CB 500 R/T	94-03	055027	130	14401-MY5-601	CMM-B	SCA0409ASDH	82RH2010	595,-	744,-
CBF 500 (PC39)	04-08	055027	130	14401-MY5-601	CMM-B	SCA0409ASDH	82RH2010	595,-	744,-
CX 500	Alle	055060	78	14401-415-003	CMM-P	SC0417HDHA	75RH2025	605,-	756,-
CX 500	77-83	055060	78	14401-415-003	CMM-P	SC0417HDHA	75RH2025	605,-	756,-
CX 500 C (PC01)	80-84	055060	78	14401-415-003	CMM-P	SC0417HDHA	75RH2025	605,-	756,-
CX 500 E Euro	82-86	055060	78	14401-415-003	CMM-P	SC0417HDHA	75RH2025	605,-	756,-
CX 500 T Turbo (PC03)	82	055060	78	14401-415-003	CMM-P	SC0417HDHA	75RH2025	605,-	756,-
GL 500 Silverwing (PC02)	81-82	055060	78	14401-415-003	CMM-P	SC0417HDHA	75RH2025	605,-	756,-
GL 500	84-87	055060	78	14401-415-003	CMM-P	SC0417HDHA	75RH2025	605,-	756,-
VF 500 F/F II	84-87	055054	146	14401-MT8-003	CMM-A	SCA0412ASDH	82RH2015	750,-	938,-
VT 500 C Shadow (PC08)	83-85	055040	116		CMM-A	SCA0412ASDH	82RH2015	585,-	731,-
VT 500 E Euro-Sport (PC11)	83-85	055040	116		CMM-A	SCA0412ASDH	82RH2015	585,-	731,-
XBR 500 (PC15)	85-87	055042	118	14401-429-003	CMM-A	SCA0412ASDH	82RH2015	610,-	763,-
XBR 500 (PC15)	88-89	055042	118	14401-429-003	CMM-A	SCA0412ASDH	82RH2015	610,-	763,-
XL 500 SZ/SA/SB/RC	79-82	055042	120	14401-429-003	CMM-A	SCA0412ASDH	82RH2015	610,-	763,-
XR 500 R (PE03)	83-84	055042	118	14401-429-003	CMM-A	SCA0412ASDH	82RH2015	610,-	763,-
CB 550 F/F1/F2/K3	78-79	055001	88	14401-323/362-003		219T		218,-	273,-
CBX 550 FC/F2/FD	81-86	055048		13414401-MA7-000	CMM-A	SCA0412ASDH	82RH2015	695,-	869,-
CB 600 Hornet	97-10	055077	116	14401-MAL-601/602	CMM-E	SCR0412SDH	92RH2015	558,-	698,-
CBF 600 N/S	04-10	055077	116	14401-MAL-601/602	CMM-E	SCR0412SDH	92RH2015	558,-	698,-
CBR 600 FH/FJ/FK/FL	87-90	055045	126	14401-MN4/438/014/MA3-003	CMM-A	SCA0412ASDH	82RH2015	645,-	806,-
CBR 600 FM/FT/FV/FW/FY/W	91-05	055077	116	14401-MF5/MV9-003	CMM-E	SCR0412SDH	92RH2015	558,-	698,-
CBR 600 RR	03-10	055077	116	14401-MAL-601/602	CMM-E	SCR0412SDH	92RH2015	558,-	698,-
VT 600 C/CN/CT Shadow	88-07	055042	118	14401-MN1-671	CMM-A	SCA0412ASDH	82RH2015	610,-	763,-
XL 600 LMF/LMH	85/87	055042	118	14401-MG3/MK4-003	CMM-A	SCA0412ASDH	82RH2015	610,-	763,-
XL 600 RD/RE/RF/RG	83/86	055042	118	14401-MG3/MK4-003	CMM-A	SCA0412ASDH	82RH2015	610,-	763,-
XL 600 VH/Trans Alp	87	055042	118	14401-MG3/MK4-003	CMM-A	SCA0412ASDH	82RH2015	610,-	763,-
XL 600 VJ/VT Trans Alp	88-00	055024	118	14401-MN1-671	CMM-B	SCA0409ASDH	82RH2010	510,-	638,-
XR 600 RJ/RT	88-00	055024	118	14401-MN1-671	CMM-B	SCA0409ASDH	82RH2010	510,-	638,-
CB 650 C (RC05)	80-81	055040	112	14401-426-004	CMM-A	SCA0412ASDH	82RH2015	585,-	731,-
CB 650 Z/ZB	79-82	055040	112	14401-426-004	CMM-A	SCA0412ASDH	82RH2015	585,-	731,-
CBX 650 E (RC15)	83-85	055054	144		CMM-A	SCA0412ASDH	82RH2015	750,-	938,-
CX 650 ED	82	055060	78	14401-415-003	CMM-P	SC0417HDHA	75RH2025	605,-	756,-
CX 650 C (RC11)	83	055060	78	14401-415-003	CMM-P	SC0417HDHA	75RH2025	605,-	756,-
CX 650 Euro (RC12)	83	055060	78	14401-415-003	CMM-P	SC0417HDHA	75RH2025	605,-	756,-
CX 650 Turbo (RC16)	83	055060	78	14401-415-003	CMM-P	SC0417HDHA	75RH2025	605,-	756,-
GL 650 D Silverwing (RC10)	83	055060	78	14401-415-003	CMM-P	SC0417HDHA	75RH2025	605,-	756,-
GL 650 Silver Wing	84>	055060	78	14401-ME//MA1-003	CMM-P	SC0417HDHA	75RH2025	605,-	756,-
NT 650 Hawk (RC31)	89-91	055024	118	14401-MN1-671	CMM-B	SCA0409ASDH	82RH2010	510,-	638,-
NT 650 V Deauville (RC47)	98-01	055024	118	14401-MN1-671	CMM-B	SCA0409ASDH	82RH2010	510,-	638,-
NT 650 V Deauville (RC47)	02-05	055068	118		CMM-J	SCR0409SDH	92RH2010	485,-	606,-
NTV 650 Revere	93-97	055024	118	14401-MN1-671	CMM-B	SCA0409ASDH	82RH2010	510,-	638,-
NTV 650 Revere (RC33)	88-97	055024		14401-MN1-671	CMM-B	SCA0409ASDH	82RH2010	510,-	638,-
NX 650 J/T Dominator (RD02)	88-94	055024	118	14401-MN1-671	CMM-B	SCA0409ASDH	82RH2010	510,-	638,-
NX 650 Dominator (RD08)	95-00	055068	118		CMM-J	SCR0409SDH	92RH2010	485,-	606,-
XL 650 V Transalp (RD10/11)	00-05	055068	118		CMM-J	SCR0409SDH	92RH2010	485,-	606,-
XR 650	00-07	055068	122		CMM-J	SCR0409SDH	92RH2010	485,-	606,-
XR 650	93-09	055024	118	14401-MN1-671	CMM-B	SCA0409ASDH	82RH2010	510,-	638,-

- Stikord
Sökord
s. 2-5
- Forhandlere
Återförsäljare
s. 6-9
- Töj/hjelme
Kläder/
hjälmor
s. 11
- Däck
Däck
s. 83
- Olje
Olja
s. 115
- Kæde/
tandhjul
Kedjor/
drev
s. 145
- Bremser
Broms
s. 187
- Låse
Lås
s. 347
- Batteri
Batterier
s. 355
- Pakninger
Packningar
s. 377
- Motordele**
Motordelar
s. 411
- Lejer
Lager
s. 435
- Karburator
Förgasare
s. 467
- El-dele/
Tænding
Elektrisk/
Tænding
s. 509
- Blinklygter
Baglygter
Belysning
Baklygter
s. 611
- Lyddæmper
Avgassystem
s. 651
- Støddæmper
Støtdæmpere
s. 681
- Luft/
oljefilter
Luft/
oljefilter
s. 711
- Kobling
Koppling
s. 769
- Kabler
Wire
s. 803
- Styr/greb
Styre/
handtag
s. 829
- Spejle
og diverse
Speglar
och diverse
s. 867
- Bøger/
værktøj
Böcker/
verktyg
s. 893

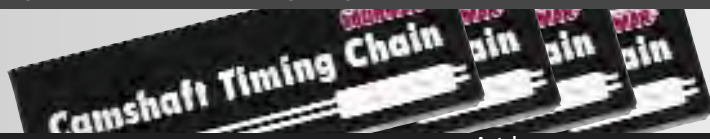

Made in Japan

Märke/ modell	Årg.	Varenr.	Antal led	OEM-nr.	Tourmax-nr.	DID-nr.	Borgvarna-nr.		
Märke/ modell	Årg.	Art.nr.	Antal länk.	OEM-nr.	Tourmax-nr.	DID-nr.	Borgvarna-nr.	DKK	SEK

HONDA									
SLR 650	97-00	055024	118	14401-MAK-003	CMM-B	SCA0409ASDH	82RH2010	510,-	638:-
XRV 650 Africa Twin (RD03)	88-89	055024	118	14401-MAK-003	CMM-B	SCA0409ASDH	82RH2010	510,-	638:-
XR 650 L (RD06)	93-04	055024	118	14401-MAK-003	CMM-B	SCA0409ASDH	82RH2010	510,-	638:-
XR 650 R (RE01)	00-05	055068	122		CMM-J	SCR0409SDH	92RH2010	485,-	606:-
NT 700 V Deauville	06-08	055068	118		CMM-J	SCR0409SDH	92RH2010	485,-	606:-
NT 700	06-10	055070	118		CMM-J	SCR0409SDH	92RH2010	458,-	573:-
CB 750 K1/K2/K6/K7	71-78	055003	94	14401-286-003		219T		255,-	319:-
CB 750 F1/F2	76-79	055003	94	14401-286-003		219T		255,-	319:-
CB 750 FZ/FA/FB/FC/F2/FD	79-84	055045	124	14401-425-014	CMM-A	SCA0412ASDH	82RH2015	645,-	806:-
CB 750 FZ/FA/FB/FC/F2/FD	79-84	055031	82	14402-438-004	CMM-A	SCA0412ASDH	82RH2015	385,-	481:-
CB 750 KZ	79-81	055045	124	14401-425-014	CMM-A	SCA0412ASDH	82RH2015	645,-	806:-
CB 750 KZ	79-81	055031	82	14402-438-004	CMM-A	SCA0412ASDH	82RH2015	385,-	481:-
CB 750 Seven Fifty	92-02	055054	146	14401-MJ0-003	CMM-E	SCR0412SDH	92RH2015	750,-	938:-
CBX 750 FE/FG/F2	84-86	055054	146	14401-MJ0-003	CMM-A	SCA0412ASDH	82RH2015	750,-	938:-
VF 750 C Magna (RC09)	82-84	055054	148		CMM-A	SCA0412ASDH	82RH2015	750,-	938:-
VF 750 C (RC43)	93-00	055067	128		CMM-E	SCR0412SDH	92RH2015	715,-	894:-
VF 750 F Interceptor (RC15)	83-85	055054	148	14401-MB0-003	CMM-A	SCA0412ASDH	82RH2015	750,-	938:-
VF 750 CH/CJ/FD/FE/FF/SC	82-88	055054	148	14401-MB0-003	CMM-A	SCA0412ASDH	82RH2015	750,-	938:-
VF 750 CP/R/S	93-96	055045	128	14401-M25-003/921	CMM-A	SCA0412ASDH	82RH2015	645,-	806:-
VF 750 S Sabre (RC07)	82-85	055054	148	14401-MB0-003	CMM-A	SCA0412ASDH	82RH2015	750,-	938:-
VT 750 C (RC14/29)	83-89	055054	148	14401-MB0-003	CMM-A	SCA0412ASDH	82RH2015	750,-	938:-
VT 750 C Shadow (RC44)	97-00	055024	118	14401-MN1-671	CMM-B	SCA0409ASDH	82RH2010	510,-	638:-
VT 750 C Shadow (RC50)	01-05	055068	118		CMM-J	SCR0409SDH	92RH2010	485,-	606:-
VT 750 C2	97-07	055024	118	14401-MN1-671	CMM-B	SCA0409ASDH	82RH2010	510,-	638:-
VT 750 C2 Ace (RC44)	97-00	055024	118	14401-MN1-671	CMM-B	SCA0409ASDH	82RH2010	510,-	638:-
VT 750 C2 Ace (RC44)	01-09	055068	118		CMM-J	SCR0409SDH	92RH2010	485,-	606:-
VT 750 DC Black Widow (RC48)	01-09	055068	118		CMM-J	SCR0409SDH	92RH2010	485,-	606:-
XRV 750 African Twin	90-01	055024	118	14401-MN1-671	CMM-B	SCA0409ASDH	82RH2010	510,-	638:-
VT 800 C Shadow	88	055045	128		CMM-A	SCA0412ASDH	82RH2015	645,-	806:-
CB 900 F2/FA/FB/FC/FD/F2D	79-84	055045	126	14401-438-014	CMM-A	SCA0412ASDH	82RH2015	645,-	806:-
CB 900 F2/FA/FB/FC/FD/F2D	79-84	055031	82	14402-438-004	CMM-A	SCA0412ASDH	82RH2015	385,-	481:-
CB 900 F Hornet	02-07	055045	126	14404-MW0-003	CMM-A	SCA0412ASDH	82RH2015	645,-	806:-
CBR 900 RR	92-99	055045	126	14401-MW0-003	CMM-A	SCA0412ASDH	82RH2015	645,-	806:-
CBR 900 RR	00-03	055067	126	14401-MAT-003	CMM-E	SCR0412SDH	92RH2015	715,-	894:-
CB 1000 Big One (SC30)	93-96	055054	150		CMM-A	SCA0412ASDH	82RH2015	750,-	938:-
CB 1000 R/RA	09	055078	126		CMM-E	SCR0412SDH	92RH2015	838,-	1048:-
CBF 1000	06-07	055045	126	14404-MW0-003	CMM-A	SCA0412ASDH	82RH2015	645,-	806:-
CBF 1000	06-10	055078	126		CMM-E	SCR0412SDH	92RH2015	838,-	1048:-
CBR 1000 FH/FT	87-00	055054	150	14401-MM5-005	CMM-A	SCA0412ASDH	82RH2015	750,-	938:-
CBR 1000 RR	04-07	055045	126		CMM-A	SCA0412ASDH	82RH2015	645,-	806:-
CBR 1000 RR	09-10	055078	124		CMM-K	-	92RH2020	838,-	1048:-
CBX 1000 Z/B/C ProLink	79-84	055042	120	14401-429-003	CMM-A	SCA0412ASDH	82RH2015	610,-	763:-
CBX 1000 Z/B/C ProLink	79-84	055031	82	14402-438-004	CMM-A	SCA0412ASDH	82RH2015	385,-	481:-
VF 1000 FE/FF/F2	84-88	055045	122	14401-MB6-003	CMM-A	SCA0412ASDH	82RH2015	645,-	806:-
VTR 1000	97-07	055078	152	14401-MBB-003	CMM-K	-	92RH2020	838,-	1048:-
VTR 1000 F (SC36)	97-07	055078	152	14401-MBB-003	CMM-K	-	92RH2020	838,-	1048:-
XL 1000 X Varadero	99-08	055078	152		CMM-K	-	92RH2020	838,-	1048:-
CB 1100 F/R	81-84	055045	126	14401-MN4-003	CMM-A	SCA0412ASDH	82RH2015	645,-	806:-
CB 1100 F/R	81-84	055031	82	14402-438-004	CMM-A	SCA0412ASDH	82RH2015	385,-	481:-
CB 1100 SF X-eleven	00-03	055067	130		CMM-E	SCR0412SDH	92RH2015	715,-	894:-
CBR 1100 XX	97-07	055067	130	14401-MAT-003	CMM-E	SCR0412SDH	92RH2015	715,-	894:-
VF 1100 C Magna (SC12)	84-87	055056	154		CMM-A	SCA0412ASDH	82RH2015	710,-	888:-
VT 1100 C Shadow (SC23)	85-04	055048	136	14401-MG8-003	CMM-A	SCA0412ASDH	82RH2015	695,-	869:-
CB 1300 A/S	05-09	055080	146		CMM-E	SCR0412SDH	92RH2015	715,-	894:-
ST 1300 A	02-09	055079	138		CMM-J	SCR0409SDH	92RH2010	635,-	794:-
VTX 1300/C	03-09	055080	140		CMM-E	SCR0412SDH	92RH2015	715,-	894:-
GL 1800	01-08	055068	118	14401-MAN-621	CMM-J	SCR0409SDH	92RH2010	485,-	606:-
VTX 1800	02-07	055080	148		CMM-E	SCR0412SDH	92RH2015	715,-	894:-

HYOSUNG									
GT 125 R	05-11	055068	124	12760-IGE00	CMM-J	SCR0409SDH	92RH2010	485,-	606:-
GT 125 N	05-11	055068	124	12760-IGE00	CMM-J	SCR0409SDH	92RH2010	485,-	606:-
GV 125	05-11	055068	124	12760-IGE00	CMM-J	SCR0409SDH	92RH2010	485,-	606:-
GT 250 R	05-11	055068	124	12760-IGE00	CMM-J	SCR0409SDH	92RH2010	485,-	606:-
GT 250 N	06-11	055068	124	12760-IGE00	CMM-J	SCR0409SDH	92RH2010	485,-	606:-
GV 250	04-11	055068	124	12760-IGE00	CMM-J	SCR0409SDH	92RH2010	485,-	606:-
TE 450	08-11	055068	132	12760-HP8900	CMM-J	SCR0409SDH	92RH2010	485,-	606:-
GT 650 R	04-11	055068	138	12760-HN9100	CMM-J	SCR0409SDH	92RH2010	485,-	606:-
Gt 650 N	04-11	055068	138	12760-HN9100	CMM-J	SCR0409SDH	92RH2010	485,-	606:-
GT 650 S	04-07	055068	138	12760-HN9100	CMM-J	SCR0409SDH	92RH2010	485,-	606:-
GV 650	05-11	055068	138	12760-HN9100	CMM-J	SCR0409SDH	92RH2010	485,-	606:-
ST 7	10-11	055068	138	12760-HN9100	CMM-J	SCR0409SDH	92RH2010	485,-	606:-

HUSQVARNA									
350 TE	90-97	055007	96		CCM-HD	219FTH	BF05MA	345,-	431:-
4010 TE	95-98	055007	96		CCM-HD	219FTH	BF05MA	345,-	431:-
610 TC	91-98	055007	100		CCM-HD	219FTH	BF05MA	345,-	431:-
610 TE	91-98	055007	100		CCM-HD	219FTH	BF05MA	345,-	431:-

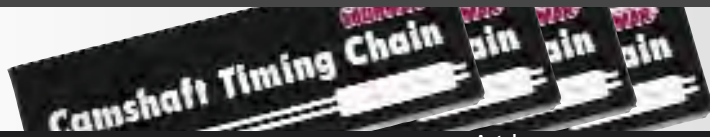

Made in Japan

Märke/ modell	Årg.	Varenr.	Antal led	OEM-nr.	Tourmax-nr.	DID-nr.	Borgvarna-nr.		
Märke/ modell	Årg.	Art.nr.	Antal länk.	OEM-nr.	Tourmax-nr.	DID-nr.	Borgvarna-nr.	DKK	SEK
KAWASAKI									
BN 125 Eliminator	98>	055074	102		CMM-J	SCR0409SDH	2RH2010	560,-	700:-
ZZR 250	90-94	055027	124	92057-1210	CMM-B	SCA0409ASDH	82RH2010	595,-	744:-
Ninja 250 R	08-09	055085	124		CMM-FF		98XRH2010	595,-	744:-
KLR 250 D2/4/5/7/8/11 (KL250D2-22)	85-05	055081	158	92057-1170	CMM-B	SCA0409ASDH	82RH2010	595,-	744:-
KLX 250 R (KLX250D)	93-96	055068	128		CMM-J	SCR0409SDH	92RH2010	485,-	606:-
KLX 250 E (LX250E)	93-95	055068	128		CMM-J	SCR0409SDH	92RH2010	485,-	606:-
KLX 250 S	09-10	055079	128		CMM-J	SCR0409SDH	92RH2010	635,-	794:-
Z 400 Twin	80-84	055040	114		CMM-A	SCA0412ASDH	82RH2015	585,-	731:-
Z 400 B1/B2/G1	75-80	055064	88	92057-21070	CMM-W	OST	BFO5T	260,-	325:-
Z 400 J 1/2/3	80-84	055054	140	92057-1027	CMM-A	SCA0412ASDH	82RH2015	750,-	938:-
ZXR 400 L	90-01	055024	118	92057-1328	CMM-B	SCA0409ASDH	82RH2010	510,-	638:-
Z 440 Twin	80-84	055040	114		CMM-A	SCA0412ASDH	82RH2015	585,-	731:-
KLX 450 A	08-10	055085	124		CMM-FF		98XRH2010	465,-	581:-
EN 500 A1/A2/A3/B1/C1 Vulcan	90-08	055054	148	92057-1188	CMM-A	SCA0412ASDH	82RH2015	750,-	938:-
ER 5	97-05	055054	148	92057-1188	CMM-A	SCA0412ASDH	82RH2015	750,-	938:-
GPZ 500 S	87-06	055054	148	92057-1188	CMM-A	SCA0412ASDH	82RH2015	750,-	938:-
KLE 500 A1/A5	91-07	055054	148	92057-1188	CMM-A	SCA0412ASDH	82RH2015	750,-	938:-
Z500 B1/B2	79-80	055054	140	92057-1027	CMM-A	SCA0412ASDH	82RH2015	750,-	938:-
Z 550 A1/A2/A3/C1/C2	80-84	055054	140	92057-1027	CMM-A	SCA0412ASDH	82RH2015	750,-	938:-
GPZ 550 D1/H1/H2 Uni trak	81-83	055054	140	92057-1027	CMM-A	SCA0412ASDH	82RH2015	750,-	938:-
Z 550 F/A1/A2 uni trak	83-88	055054	140	92057-1027	CMM-A	SCA0412ASDH	82RH2015	750,-	938:-
ZR 550 B2/B6 Zephyr	91-99	055054	140	92057-1027	CMM-A	SCA0412ASDH	82RH2015	750,-	938:-
ZX 550 A1/2/3/4/5 Uni Trak	83-92	055054	140	92057-1027	CMM-A	SCA0412ASDH	82RH2015	750,-	938:-
KL 600/KLR 600	84-90	055059	172	92057-1176	CMM-A	SCA0412ASDH	82RH2015	695,-	869:-
GPZ 600 R	85-90	055027	136	92057-1190	CMM-B	SCA0409ASDH	82RH2010	595,-	744:-
GPX 600	88-97	055027	136	92057-1190	CMM-B	SCA0409ASDH	82RH2010	595,-	744:-
ZL 600 Eliminator (ZL600A/B)	86-98	055027	136	92057-1190	CMM-B	SCA0409ASDH	82RH2010	595,-	744:-
ZX 6 R	95-06	055027	122	92057-1397	CMM-B	SCA0409ASDH	82RH2010	595,-	744:-
ZX 600	03-08	055067	126	92057-1453	CMM-E	SCR0412SDH	92RH2015	715,-	894:-
ZZR 600 Ninja (ZX600D/E)	90-04	055048	132	92057/1297	CMM-A	SCA0412ASDH	82RH2015	695,-	869:-
ZZR 600 Ninja (ZX600J5/6F)	05-08	055067	122	92057-1453	CMM-E	SCR0412SDH	92RH2015	715,-	894:-
ZX 6 R (ZX600F/G/I)	95-02	055067	122	92057-1453	CMM-E	SCR0412SDH	92RH2015	715,-	894:-
ZX 6 R	03-10	055067	126	92057-1453	CMM-E	SCR0412SDH	92RH2015	715,-	894:-
ER-6 N/F (EX650A)	05-10	055080	134	92057-1010	CMM-E	SCR0412SDH	92RH2015	715,-	894:-
ZX 636 R (ZX636A1)	02	055067	122	92057-1397	CMM-E	SCR0412SDH	92RH2015	715,-	894:-
ZX 636 R	03-06	055085	116		CMM-FF		98XRH2010	465,-	581:-
KL 650/KLR 650	89-91	055059	174	92057-1226	CMM-A	SCA0412ASDH	82RH2015	695,-	869:-
KLR 650 C1-C5	95-08	055082	174		CMM-E	SCR0412SDH	92RH2015	760,-	950:-
KLE 650 Versys	07-09	055080	134		CMM-E	SCR0412SDH	92RH2015	715,-	894:-
Z 650 B1/2/3/C2/C3/D2	76-79	055064	118	92057-012	CMM-W	OST	BFO5T	260,-	325:-
Z 650 D3/F1/F2/F3/F4	80-83	055054	150	92057-1033	CMM-A	SCA0412ASDH	82RH2015	750,-	938:-
Z 750 B1/B2 2 cyl.	76>	055083	130	92057-11	CMM-W	OST	BFO5T	415,-	519:-
Z 750 E1/H1/H2/L1/L2/L3/L4	80-87	055054	150	92057-1033	CMM-A	SCA0412ASDH	82RH2015	750,-	938:-
ZR 750 Zephyr	91-99	055054	150	92057-1033	CMM-A	SCA0412ASDH	82RH2015	750,-	938:-
GPZ 750 Uni Trak	83-87	055054	150	92057-1033	CMM-A	SCA0412ASDH	82RH2015	750,-	938:-
GPZ 750 Turbo	83-87	055054	150	92057-1033	CMM-A	SCA0412ASDH	82RH2015	750,-	938:-
GPX 750	87-92	055048	138	92057-1220	CMM-A	SCA0412ASDH	82RH2015	695,-	869:-
ZXR 750 H1/H2	89-90	055048	138	92057-1220	CMM-A	SCA0412ASDH	82RH2015	695,-	869:-
ZXR 750 J1/J2	91-92	055013	106	92057-1323	CMM-G	219FTSSDHA	BF05M	338,-	423:-
ZXR 750 R/RR	91-95	055013	106	92057-1323	CMM-G	219FTSSDHA	BF05M	338,-	423:-
ZXR 750	93-95	055013	106	92057-1323	CMM-G	219FTSSDHA	BF05M	338,-	423:-
ZX 7 R	96-01	055013	104	92057-1415	CMM-G	219FTSSDHA	BF05M	338,-	423:-
ZR-7/S	99-03	055054	150	92057-1319	CMM-A	SCA0412ASDH	82RH2015	750,-	938:-
Z 750 (ZR 750 J)	04-10	055067	126	92057-1453	CMM-E	SCR0412SDH	92RH2015	715,-	894:-
Z 750/S	05-09	055067	126	92057-1453	CMM-E	SCR0412SDH	92RH2015	715,-	894:-
VN 750 Vulcan	86-05	055072	82		CMM-A	SCA0412ASDH	82RH2015	588,-	735:-
VN 800/Classic/Drifter	95-06	055068	124	92057-1403	CMM-J	SCR0409SDH	92RH2010	485,-	606:-
VN 900 B/C	06-10	055068	124	92057-1403	CMM-J	SCR0409SDH	92RH2010	485,-	606:-
Z 900 A1/2/3/4\$	73-78	055004	122	92057-003		219T		299,-	374:-
ZL 900 Eliminator	85-87	055062	118	92057-1160	CMM-C	SC-2515DHA	81RH2515	670,-	838:-
GPZ 900 R	84-96	055062	118	92057-1160	CMM-C	SC-2515DHA	81RH2515	670,-	838:-
ZX 9 R	94-97	055080	134	92057-1384	CMM-E	SCR0412SDH	92RH2015	715,-	894:-
ZX 9 R	98-03	055067	126	92057-1453	CMM-E	SCR0412SDH	92RH2015	715,-	894:-
Z 1000	77-82	055004	122	92057-003		219T		299,-	374:-
Z 1000 J1-2-3/R	81-84	055056	152	92057-1052	CMM-A	SCA0412ASDH	82RH2015	710,-	888:-
Z 1000 /ABS / ZR 1000	03-10	055067	126	92057-1453	CMM-E	SCR0412SDH	92RH2015	715,-	894:-
ZL 1000 Eliminator	87-89	055062	118	92057-1160	CMM-C	SC-2515DHA	81RH2515	670,-	838:-
GTR 1000	86-06	055062	118	92057-1160	CMM-C	SC-2515DHA	81RH2515	670,-	838:-
GPZ 1000 RX	86-89	055062	118	92057-1160	CMM-C	SC-2515DHA	81RH2515	670,-	838:-
ZX 10 B1-2-3	88-91	055062	114	92057-1255	CMM-C	SC-2515DHA	81RH2515	670,-	838:-
ZX-10 R	04-10		124	92057-0085	CMM-L				
Z 1100 A1-2-3/B1-2/R1	81-86	055056	152	92057-1052	CMM-A	SCA0412ASDH	82RH2015	710,-	888:-
GPZ 1100 Uni trak	83-85	055056	152	92057-1052	CMM-A	SCA0412ASDH	82RH2015	710,-	888:-
GPZ 1100	95-97	055062	114	92057-1255	CMM-C	SC-2515DHA	81RH2515	670,-	838:-
ZR 1100 Zephyr	92-95	055063	132	92057-1353	CMM-C	SC-2515DHA	81RH2515	665,-	831:-
ZR 1000 B	07-09	055080	126		CMM-A	SCA0412ASDH	82RH2015	715,-	894:-
ZZR 1100 C1-2-3/D1-4	90-01	055062	114	92057-1255	CMM-C	SC-2515DHA	81RH2515	670,-	838:-

- Stikord
Sökord
s. 2-5
- Forhandlere
Återförsäljare
s. 6-9
- Töj/hjelme
Kläder/
hjälmor
s. 11
- Däck
Däck
s. 83
- Olje
Olja
s. 115
- Kæde/
tandhjul
Kedjor/
drev
s. 145
- Bremser
Broms
s. 187
- Låse
Lås
s. 347
- Batteri
Batterier
s. 355
- Pakninger
Packningar
s. 377
- Motordele**
Motordele
s. 411
- Lejer
Lager
s. 435
- Karburator
Förgasare
s. 467
- El-dele/
Tænding
Elektrisk/
Tænding
s. 509
- Blinklygter
Baglygter
Belysning
Baklykter
s. 611
- Lyddæmper
Avgassystem
s. 651
- Støddæmper
Støtdæmpere
s. 681
- Luft/
oliefilter
Luft/
oljefilter
s. 711
- Kobling
Koppling
s. 769
- Kabler
Wire
s. 803
- Styr/greb
Styre/
handtag
s. 829
- Spejle
og diverse
Speglar
och diverse
s. 867
- Bøger/
værktøj
Böcker/
verktyg
s. 893

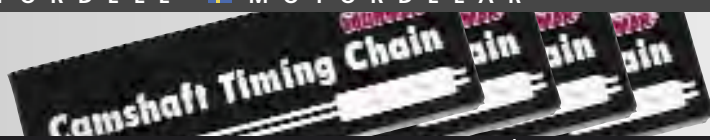

Made in Japan

Märke/ modell	Årg.	Varenr.	Antal led	OEM-nr.	Tourmax-nr.	DID-nr.	Borgvarna-nr.		
Märke/ modell	Årg.	Art.nr.	Antal länk.	OEM-nr.	Tourmax-nr.	DID-nr.	Borgvarna-nr.	DKK	SEK

KAWASAKI

ZRX 1100	99-00	055062	114	92057-1255	CMM-C	SC-2515DHA	81RH2515	670,-	838:-
ZRX 1200	01-07	055062	114	92057-1255	CMM-C	SC-2515DHA	81RH2515	670,-	838:-
ZX 12 R A1-A2/B1-B2	00-05	055080	132	92057-1475	CMM-E	SCR0412SDH	92RH2015	715,-	894:-
ZZR 1200	02-05	055062	114	92057-1255	CMM-C	SC-2515DHA	81RH2515	670,-	838:-
Z 1300 A1-2-3-4-5	79-83	055058	158	92057-1018	CMM-A	SCA0412ASDH	82RH2015	725,-	906:-
ZG 1300 A1-2-3	84-90	055058	158	92057-1018	CMM-A	SCA0412ASDH	82RH2015	725,-	906:-
ZZR 1400	06-08	055067	130	92057-0109	CMM-E	SCR0412SDH	92RH2015	715,-	894:-
VN 1500	88-08	055079	144	92057-1234	CMM-J	SCR0409SDH	92RH2010	635,-	794:-
VN 1600	03-08	055079	144	92057-1234	CMM-J	SCR0409SDH	92RH2010	635,-	794:-
VN 1700	09-10		146		CMM-FF		98XRH2010		
VN 2000	04-10		70	92057-0026	CMM-L				

KTM

450	08-09		80				98XRH2015		
SMR 450	08-09		80				98XRH2015		
SX-F 450	08-09		80				98XRH2015		
SXS-F XC-F 450	08-09		80				98XRH2015		
SX-F 505	08-09		80				98XRH2015		
XC-F 505	08-09		80				98XRH2015		
SXS-F 505	08-09		80				98XRH2015		
Adventure 950	03-06	055069	88		CMM-E	SCR0412SDH	92RH2015	425,-	531:-
Duke 950	04	055069	88		CMM-E	SCR0412SDH	92RH2015	425,-	531:-
Supermoto 950	05-06	055069	88		CMM-E	SCR0412SDH	92RH2015	425,-	531:-
Superduke 990	05-06	055069	88		CMM-E	SCR0412SDH	92RH2015	425,-	531:-

MOTO GUZZI

Griso 8V - 1200 Sport 4V	Alle	055069	84		CMM-E	SCR0412SDH	92RH2015	425,-	531:-
Stelvio 4V 1200cc	Alle	055069	84		CMM-E	SCR0412SDH	92RH2015	425,-	531:-

PIAGGIO

Liberty 50	00-02		84		CCM-Y	-	92RH2005		
Vespa 50 ET4	00-02		84		CCM-Y	-	92RH2005		
Zip 50	00-02		84		CCM-Y	-	92RH2005		
Liberty 125	98-02		88		CCM-Y	-	92RH2005		
Liberty 125	03		94		CCM-Y	-	92RH2005		
Beverly 125	01-03		96		CCM-Y	-	92RH2005		
Hexagon 125	99-01		94		CCM-Y	-	92RH2005		
Super Hexagon 125	01-04		96		CCM-Y	-	92RH2005		
Sfera 125	99-00		88		CCM-Y	-	92RH2005		
Vespa 125 ET4	96-00		88		CCM-Y	-	92RH2005		
Zip 125	00-02		94		CCM-Y	-	92RH2005		
Fly 150	05		94		CCM-Y	-	92RH2005		
Hexagon 150	99-02		96		CCM-Y	-	92RH2005		
Liberty 150	01-03		94		CCM-Y	-	92RH2005		
Skipper 150 ST	00-02		94		CCM-Y	-	92RH2005		
X9 Amalfi 180	00-02		96		CCM-Y	-	92RH2005		
Beverly 200	01-03		96		CCM-Y	-	92RH2005		
Liberty 200	04-05		94		CCM-Y	-	92RH2005		
Vespa GT 200 L	03-04		96		CCM-Y	-	92RH2005		
X8 200	04-06		96		CCM-Y	-	92RH2005		
GTX 250	00-02		102		CCM-Y	-	92RH2005		
Hexagon 250	99-02		102		CCM-Y	-	92RH2005		
Versity 300	03-05		104				82RH2005		
Beverly 500	03-04	055070	106		CCM-J	SCR0409SDH	92RH2010	458,-	573:-
X9 500	01-04		96		CCM-Y	-	92RH2005		

SUZUKI

GN 125	93-97		98	12750-44A00		25SHDHA			
DR-Z 125 L	03-10		98			25SHDHA			
AN 250 Burgman	98-06	055024	108	12760-19B70	CMM-B	SCA0409ASDH	82RH2010	510,-	638:-
DR 250 (SG442A)	82-85	055040	112	12760-13F00	CMM-A	SCA0412ASDH	82RH2015	585,-	731:-
DR-Z 250	01-04	055067	128	12760-32E00	CMM-E	SCR0412SDH	92RH2015	715,-	894:-
GN 250 (NJ42A)	82-99	055040	112	12760-38200	CMM-A	SCA0412ASDH	82RH2015	585,-	731:-
GSX 250 ET/EX/EZ	79-85	055016	114	12760-11460	CMM-G	219FTSSDHA	BF05M	365,-	456:-
GSX R 250	90>	055024	114	12760-05C00	CMM-B	SCA0409ASDH	82RH2010	510,-	638:-
GZ 250 Marauder	99-08	055040	112	12760-13F00	CMM-A	SCA0412ASDH	82RH2015	585,-	731:-
VL 250 Intruder	06>	055070	104		CCM-J	SCR0409SDH	92RH2010	458,-	573:-
TU 250 XV	97-99	055040	112	12760-11460	CMM-A	SCA0412ASDH	82RH2015	585,-	731:-
DR 350	90-98	055024	108	12760-19B70	CMM-B	SCA0409ASDH	82RH2010	510,-	638:-
AN 400 Burgman	03-06	055024	108	12760-19B71/19F00	CMM-B	SCA0409ASDH	82RH2010	510,-	638:-
AN 400 Burgman	07-10	055081	136		CMM-B	SCA0409ASDH	82RH2010	595,-	744:-
GN 400	80-82	055013	98	12760-32410	CMM-G	219FTSSDHA	BF05M	338,-	423:-
DR-Z 400/S/E/SM	00-09	055027	128	12760-29F01	CMM-B	SCA0409ASDH	82RH2010	595,-	744:-
DR-Z 400 Motard	05-09	055027	128	12760-29F01	CMM-B	SCA0409ASDH	82RH2010	595,-	744:-
GS 400/425	77-79	055019	120	12760-45040	CMM-G	219FTSSDHA	BF05M	385,-	481:-
GSX 400 ET/EX/EZ/LX/TX	81-85	055019	120	12760-45040	CMM-G	219FTSSDHA	BF05M	385,-	481:-
GSX 400 FX/FZ/FD	81-86	055048	138	12760-33200	CMM-A	SCA0412ASDH	82RH2015	695,-	869:-
GSX R 400	87>	055037	110	12760-30B10	CMM-A	SCA0412ASDH	82RH2015	510,-	638:-

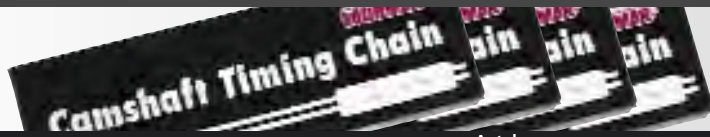

Made in Japan

Märke/ modell	Årg.	Varenr.	Antal led	OEM-nr.	Tourmax-nr.	DID-nr.	Borgvarna-nr.		
Märke/ modell	Årg.	Art.nr.	Antal länk.	OEM-nr.	Tourmax-nr.	DID-nr.	Borgvarna-nr.	DKK	SEK
SUZUKI									
GSF 400 Bandit	91-95	055062	118	12760-32C01	CMM-S	215FDHA	BF04MA	670,-	838:-
GSX R 400 E/T	81-85	055013	106	12760-32C01	CMM-G	219FTSSDHA	BF05M	338,-	423:-
GSX 400 Impulse	87->	055013	106	12760-30B01	CMM-G	219FTSSDHA	BF05M	338,-	423:-
GS 450 ET/EG/EH/EJ	80-89	055019	120	12760-45040	CMM-G	219FTSSDHA	BF05M	385,-	481:-
DR 500	81-86	055045	124	12760-37400	CMM-A	SCA0412ASDH	82RH2015	645,-	806:-
GS 500 E	89-06	055019	120	12760-45040	CMM-G	219FTSSDHA	BF05M	385,-	481:-
GS 500 F	04-08	055019	120	12760-45040	CMM-G	219FTSSDHA	BF05M	385,-	481:-
GS 550 C/EC/N/EN/EX/EZ/LT/LX/MX	77-84	055019	116	12760-47040	CMM-G	219FTSSDHA	BF05M	385,-	481:-
GSX 550 ESD/EE	83-88	055054	144	12760-26E00	CMM-A	SCA0412ASDH	82RH2015	750,-	938:-
DR 600 SF/RG	84-87	055045	124	12760-37400	CMM-A	SCA0412ASDH	82RH2015	645,-	806:-
GSF 600 Bandit	95-05	055054	144	12760-26E00	CMM-A	SCA0412ASDH	82RH2015	750,-	938:-
GSR 600	06-10	055045	120	12760-39F00	CMM-A	SCA0412ASDH	82RH2015	645,-	806:-
GSX 600 FJ/FK/FL/FM/FN/FP/FR/FS	88-01	055007	116	12760-27A01	CMM-HD	219FTH	BF05MA	345,-	431:-
GSX 600 F	97-07	055054	144	12760-26E00	CMM-A	SCA0412ASDH	82RH2015	750,-	938:-
GSX R 600	97-00	055045	128	12760-38A00/10/11	CMM-A	SCA0412ASDH	82RH2015	645,-	806:-
GSX R 600	01-10	055045	120	12760-39F00	CMM-A	SCA0412ASDH	82RH2015	645,-	806:-
RF 600 RP/RR/RS/RT	92-98	055007	110	12760-17E00	CMM-HP	219FTH	BF05MA	345,-	431:-
VS 600 GL Intruder (VN51B)	95-97	055045	128	12760-38A11	CMM-A	SCA0412ASDH	82RH2015	645,-	806:-
AN 650 Burgman (BU)	02->	055068	136	12760-19F00	CMM-B	SCA0409ASDH	82RH2010	485,-	606:-
DL 650 V-Strom	04-10	055079	136	12760-19F00	CMM-B	SCA0409ASDH	82RH2010	635,-	794:-
DR 650 SE	91-96	055045	124	12760-37400	CMM-A	SCA0412ASDH	82RH2015	645,-	806:-
DR 650	96-06	055067	120	12760-32E00	CMM-E	SCR0412SDH	92RH2015	715,-	894:-
GS 650 GTX/GTZ/GX/GZ/GTD/Katana	81-84	055019	120	12760-45040	CMM-G	219FTSSDHA	BF05M	385,-	481:-
GSF 650 Bandit	05-06	055054	144	12760-26E00	CMM-A	SCA0412ASDH	82RH2015	750,-	938:-
GSF 650 Bandit	07-08	055054	142	12760-26E00	CMM-A	SCA0412ASDH	82RH2015	750,-	938:-
GSX 650 F	08-10	055054	142		CMM-A	SCA0412ASDH	82RH2015	750,-	938:-
LS 650 FG/PJ/PK/PM/PR	87-08	055048	132	12760-24B00	CMM-A	SCA0412ASDH	82RH2015	695,-	869:-
SV 650/S/ABS	99-08	055027	136	12760-19F00	CMM-B	SCA0409ASDH	82RH2010	595,-	744:-
XF 650 Freewind	97-02	055067	120	12760-32E00	CMM-E	SCR0412SDH	92RH2015	715,-	894:-
DR 750 SJ/SK	88-89	055037	106	12760-44B00	CMM-A	SCA0412ASDH	82RH2015	510,-	638:-
GS 750 DC/EC/N/DN/EN	77-80	055019	120	12760-45040	CMM-G	219FTSSDHA	BF05M	385,-	481:-
GSX 750 ET/T/EX/Katana	80-84	055020	122	12760-45440	CMM-G	219FTSSDHA	BF05M	387,-	484:-
GSX 750 ESD/EE/ESE	83-88	055019	120	12760-45040	CMM-G	219FTSSDHA	BF05M	385,-	481:-
GSX 750	99-03	055054	144	12760-26E00	CMM-A	SCA0412ASDH	82RH2015	750,-	938:-
GSX 750 FK/FL/FM/FN/FP/FR/FS	89-98	055009	118	12760-17C01	CMM-HD	219FTH	BF05MA	335,-	419:-
GSX 750 F	98-08	055054	144	12760-26E00	CMM-A	SCA0412ASDH	82RH2015	750,-	938:-
GSX R750 F/G/XH	85-87	055019	116	12760-47040	CMM-G	219FTSSDHA	BF05M	385,-	481:-
GSX R 750 J	88-89	055009	118	12760-17C01	CMM-HD	219FTH	BF05MA	335,-	419:-
GSX R 750 K/L/M	89-92	055007	116	12760-27A01	CMM-HD	219FTH	BF05MA	345,-	431:-
GSX R 750 WN/WP/WR/WVS	92-95	055007	110	12760-17E00	CMM-HD	219FTH	BF05MA	345,-	431:-
GSX R 750 TV/VW/X	96-99	055045	128	12760-38A10	CMM-A	SCA0412ASDH	82RH2015	645,-	806:-
GSX R 750	00-05	055045	126	12760-35F00	CMM-A	SCA0412ASDH	82RH2015	645,-	806:-
GSX R 750	06-10	055042	120	12760-39F00	CMM-A	SCA0412ASDH	82RH2015	610,-	763:-
VS 750 Intruder	85-92	055045	128	12760-38A00	CMM-A	SCA0412ASDH	82RH2015	645,-	806:-
DR 800 S (SR42/43B)	90-99	055037	106	12760-44B00	CMM-A	SCA0412ASDH	82RH2015	510,-	638:-
VL 800 Volusia	04-08	055045	128	12760-41F00	CMM-A	SCA0412ASDH	82RH2015	645,-	806:-
VL 800 Volusia for/fram	01-04	055048	132		CMM-A	SCA0412ASDH	82RH2015	695,-	869:-
bag/bak	01-04	055045	128		CMM-A	SCA0412ASDH	82RH2015	645,-	806:-
VS 800 Intruder	90-00	055045	128	12760-38A10	CMM-A	SCA0412ASDH	82RH2015	645,-	806:-
VL 800 Intruder for/fram	05->	055048	132		CMM-A	SCA0412ASDH	82RH2015	695,-	869:-
bag/bak	05->	055045	128		CMM-A	SCA0412ASDH	82RH2015	645,-	806:-
VX 800 L/M	90-97	055045	128	12760-38A10	CMM-A	SCA0412ASDH	82RH2015	645,-	806:-
VZ 800 Marauder	97-04	055045	128	12760-38A10/11	CMM-A	SCA0412ASDH	82RH2015	645,-	806:-
VZ 800 Intruder for/fram	05-09	055048	132		CMM-A	SCA0412ASDH	82RH2015	695,-	869:-
bag/bak	05-09	055045	128		CMM-A	SCA0412ASDH	82RH2015	645,-	806:-
GS 850 GF/GG/GN/GT/GX	79-84	055019	120	12760-45040	CMM-G	219FTSSDHA	BF05M	385,-	481:-
RF 900 RR/RS/RT	94-98	055007	114	12760-46E00	CMM-HD	219FTH	BF05MA	345,-	431:-
GS 1000 alle modeller	78-82	055019	120	12760-45040	CMM-G	219FTSSDHA	BF05M	385,-	481:-
GSX R 1000	01-09	055048	130	12760-40F00	CMM-A	SCA0412ASDH	82RH2015	695,-	869:-
TL 1000 S/R	97-03	055069	92	12760-02F00	CMM-E	SCR0412SDH	92RH2015	425,-	531:-
SV 1000/S	03-07	055084	92	12760-23F00	CCM-J	SCR0409SDH	92RH2010	415,-	519:-
DL 1000 V-Strom	02-10	055084	92	12760-23F00	CCM-J	SCR0409SDH	92RH2010	415,-	519:-
GS 1100 G (GU73A)	84-86	055019	120	12760-45040	CMM-G	219FTSSDHA	BF05M	385,-	481:-
GSX 1100 E/Katana	81-85	055019	120	12760-45040	CMM-G	219FTSSDHA	BF05M	385,-	481:-
GSX 1100 EF/ESD	83-88	055019	120	12760-45040	CMM-G	219FTSSDHA	BF05M	385,-	481:-
GSX 1100 FJ/FK7FL/FM/FN/FR	88-97	055009	122	12760-06B00	CMM-HD	219FTH	BF05MA	335,-	419:-
GSX 1100 GM/GN/GP	91-97	055054	150	12760-26D00	CMM-A	SCA0412ASDH	82RH2015	750,-	938:-
GSX R 1100 G/H/J	86-88	055009	122	12760-06B00	CMM-HD	219FTH	BF05MA	335,-	419:-
GSX R 1100 K/L/M/N	89-93	055009	122	12760-06B00	CMM-HD	219FTH	BF05MA	335,-	419:-
GSX R 1100 WP/WR/WS/WT	93-98	055007	114	12760-46E00	CMM-HD	219FTH	BF05MA	345,-	431:-
GSF 1200 Bandit	96-06	055054	150	12760-26D00	CMM-A	SCA0412ASDH	82RH2015	750,-	938:-
GSX 1200 X Inazuma	99-01	055054	150	12760-26D00	CMM-A	SCA0412ASDH	82RH2015	750,-	938:-
GSF 1250 Bandit	07-10	055054	142	12760-26D00	CMM-A	SCA0412ASDH	82RH2015	750,-	938:-
GSX 1300 B-King	08-09	055048	136	12760-24F00	CMM-A	SCA0412ASDH	82RH2015	695,-	869:-
GSX R 1300 Hayabusa	99-08	055048	136	12760-24F00	CMM-A	SCA0412ASDH	82RH2015	695,-	869:-
VS 1400 Intruder	87-06	055029	142	12760-38B00	CMM-B	SCA0409ASDH	82RH2010	650,-	813:-

- Stikord
Sökord
s. 2-5
- Forhandlere
Återförsäljare
s. 6-9
- Töj/hjelme
Kläder/
hjälmor
s. 11
- Däck
Däck
s. 83
- Olie
Olja
s. 115
- Kæde/
tandhjul
Kedjor/
drev
s. 145
- Bremser
Broms
s. 187
- Låse
Lås
s. 347
- Batteri
Batterier
s. 355
- Pakninger
Packningar
s. 377
- Motordele**
Motordele
s. 411
- Lejer
Lager
s. 435
- Karburator
Förgasare
s. 467
- El-dele/
Tænding
Elektrisk/
Tænding
s. 509
- Blinklygter
Baglygter
Belysning
Baklykter
s. 611
- Lyddæmper
Avgassystem
s. 651
- Støddæmper
Støtdæmpere
s. 681
- Luft-/
oljefilter
Luft-/
oljefilter
s. 711
- Kobling
Koppling
s. 769
- Kabler
Wires
s. 803
- Styr/greb
Styre/
handtag
s. 829
- Spejle
og diverse
Speglar
och diverse
s. 867
- Bøger/
værktøj
Böcker/
verktyg
s. 893

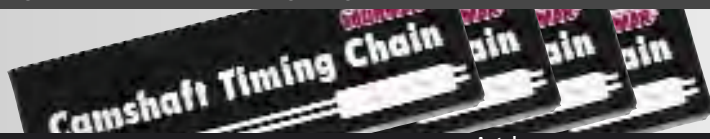

Made in Japan

Märke/ modell	Årg.	Varenr.	Antal led	OEM-nr.	Tourmax-nr.	DID-nr.	Borgvarna-nr.		
Märke/ modell	Årg.	Art.nr.	Antal länk.	OEM-nr.	Tourmax-nr.	DID-nr.	Borgvarna-nr.	DKK	SEK

SUZUKI

VL 1500 Intruder	98-08	055029	142	12760-98B00	CMM-B	SCA0409ASDH	82RH2010	670,-	813:-
VZ 1600 Marauder	04-07	055079	144	K9205-71422	CCM-J	SCR0409SDH	92RH2010	635,-	794:-
VZR 1800 Intruder / VLR 1800	06-09	055069	78	12761-48G00 NO. 1	CMM-E	SCR0412SDH	92RH2015	425,-	531:-
VZR 1800 Intruder / VLR 1800	06-09	055040	116	12761-48G00 NO. 2	CMM-A	SCA0412ASDH	82RH2015	585,-	731:-

TRIUMPH

DAYTONA 675 cc	08>	055067	126		CMM-E	SCR0412SDH	92RH2015	715,-	894:-
Alle modeller 750-1200 cc	93-98	055054	146		CMM-A	SCA0412ASDH	82RH2015	750,-	938:-
BONNEVILLE - SPEEDMASTER - THRUXTON 865 cc	09>	055078	134		CMM-E	SCR0412SDH	92RH2015	838,-	1048:-
AMERICA 865 cc	09>	055078	134		CMM-E	SCR0412SDH	92RH2015	838,-	1048:-
SCRAMBLER 865 cc	09>	055078	134		CMM-E	SCR0412SDH	92RH2015	838,-	1048:-
SPEED TRIPLE - SPRINT - TIGER 1050 cc	08>	055078	134		CMM-E	SCR0412SDH	92RH2015	838,-	1048:-
STREET TRIPLE	08>	055067	126		CMM-E	SCR0412SDH	92RH2015	715,-	894:-
THUNDERBIRD 1600 cc	Alle	055078	142		CMM-E	SCR0412SDH	92RH2015	838,-	1048:-
ROCKET III 2300 cc	07>	055082	170		CMM-E	SCR0412SDH	92RH2015	760,-	950:-

VOXAN

Alle			150		CMM-E	SCR0412SDH	92RH2015		
------	--	--	-----	--	-------	------------	----------	--	--

YAMAHA

SR 250 SE	91-98	055013	90	94500-02090	CMM-G	219FTSSDHA	BF05M	338,-	423:-
XS 250	78-85	055013	92	94500-42092-05M	CMM-G	219FTSSDHA	BF05M	338,-	423:-
XT 250	80-87	055013	90	94500-02090-05M	CMM-G	219FTSSDHA	BF05M	338,-	423:-
XV 250 Virago	95-08	055015	110	94580-25110	CMM-G	219FTSSDHA	BF05M	350,-	438:-
XT 350 / TT 350	85-98	055048	136	94590-55136	CMM-A	SCA0412ASDH	82RH2015	695,-	869:-
FZR 400 Genesis	89>	055065	110	94581-32110	CMM-S	215FDHA	-	350,-	438:-
XS 400	78-79	055013	92	94500-42092-05M	CMM-G	219FTSSDHA	BF05M	338,-	423:-
XS 400	82-85	055020	122	94500-44122	CMM-G	219FTSSDHA	BF05M	387,-	484:-
XS 400 SE	80-83	055020	122	94500-44122	CMM-G	219FTSSDHA	BF05M	387,-	484:-
XS 400 Seca	82>	055020	122	94500-44122	CMM-G	219FTSSDHA	BF05M	387,-	484:-
SR 500	78-99	055013	106	94500-02106	CMM-G	219FTSSDHA	BF05M	338,-	423:-
TT 500 G/H	79-90	055013	106	94500-02106	CMM-G	219FTSSDHA	BF05M	338,-	423:-
XP 500 T-Max	01-09	055079	132		CCM-J	SCR0409SDH	92RH2010	635,-	794:-
XT 500 G/H	75-90	055013	104	94862-81104	CMM-G	219FTSSDHA	BF05M	338,-	423:-
XT 500	76-81	055013	106	94500-02106	CMM-G	219FTSSDHA	BF05M	338,-	423:-
XV 535 Virago	88-04	055042	118	94590-44118	CMM-A	SCA0412ASDH	82RH2015	610,-	763:-
XJ 550	81-85	055016	114	94580-37114	CMM-G	219FTSSDHA	BF05M	365,-	456:-
XT 550	82-84	055045	126	94590-27126	CMM-A	SCA0412ASDH	82RH2015	645,-	806:-
XZ 550	82-84	055040	112	94590-42112	CMM-A	SCA0412ASDH	82RH2015	585,-	731:-
FZR 600 Genesis	89-97	055066	118	94581-32118	CMM-SD	215FDHA	-	550,-	688:-
FZS 600 Fazer	98-03	055068	130	94591-47130	CCM-J	SCR0409SDH	92RH2010	485,-	606:-
FZR 600 R	94-97	055066	118	94581-32118	CMM-SD	215FDHA	-	550,-	688:-
YZF 600 Thundercat	96-05	055066	118	9Y581-32117	CMM-SD	215FDHA	-	550,-	688:-
YZF R6	99-05	055067	120	94591-49120	CMM-E	SCR0412SDH	92RH2015	715,-	894:-
YZF-R6	07		118	94591-61118	CMM-L				
YZF-R6	08-10		118		CMM-LN				
YZF-R6S	06-08	055067	120	94591-49120	CMM-E	SCR0412SDH	92RH2015	715,-	894:-
FZ 6 N/S/SA/NS/SHG Fazer	04-08	055067	120	94591-49120	CMM-E	SCR0412SDH	92RH2015	715,-	894:-
XJ 600	84-92	055016	114	94580-37114	CMM-G	219FTSSDHA	BF05M	365,-	456:-
XJ 600 Diversion	92-03	055029	144	94890-04144	CMM-B	SCA0409ASDH	82RH2010	650,-	813:-
XJ 6 N/S/F Diversion	09-10		120		CMM-FN				
XT 600	84-88	055045	126	94590-27126	CMM-A	SCA0412ASDH	82RH2015	645,-	806:-
XT 600 E Tenere	83-01	055045	126	94590-27126	CMM-A	SCA0412ASDH	82RH2015	645,-	806:-
XT 600 Z Tenere	84-90	055045	126	94590-27126	CMM-A	SCA0412ASDH	82RH2015	645,-	806:-
XT 600 E	90-02	055045	126	94590-27126	CMM-A	SCA0412ASDH	82RH2015	645,-	806:-
TT 600	83-04	055045	126	94590-27126	CMM-A	SCA0412ASDH	82RH2015	645,-	806:-
XJ 650	80-85	055019	120	94500-02120	CMM-G	219FTSSDHA	BF05M	385,-	481:-
XS 650	75-81	055013	106	94500-02106	CMM-G	219FTSSDHA	BF05M	338,-	423:-
XS 650 SE	79-81	055013	106	94500-02106	CMM-G	219FTSSDHA	BF05M	338,-	423:-
XVS 650 Drag Star	97-08	055042	118	94591-41118	CMM-A	SCA0412ASDH	82RH2015	610,-	763:-
SZR 660	96-98	055045	126	94591-40126	CMM-A	SCA0412ASDH	82RH2015	645,-	806:-
XT 660 X/R/Tenere	04-10	055085	126				98XRH2010	465,-	581:-
MT-03 (660cc)	05-10	055045	126	94591-57126	CMM-A	SCA0412ASDH	82RH2015	645,-	806:-
XTZ 660 Tenere	91-99	055045	126	94590-27126	CMM-A	SCA0412ASDH	82RH2015	645,-	806:-
XJ 700 Maxim	85>	055019	120	94590-02120	CMM-G	219FTSSDHA	BF05M	365,-	481:-
FZ 750	85-93	055015	110	94580-37110	CMM-G	219FTSSDHA	BF05M	350,-	438:-
FZR 750 Genesis	87-88	055015	110	94580-37110	CMM-G	219FTSSDHA	BF05M	350,-	438:-
FZR 750 (OW 01)	89-92	055013	104	94862-81104	CMM-G	219FTSSDHA	BF05M	338,-	423:-
TX 750 2 cyl.	73-76	055022			CMM-G	219FTSSDHA	BF05M	410,-	513:-
XJ 750	84>	055019	120	94500-02120	CMM-G	219FTSSDHA	BF05M	385,-	481:-
XJ 750 Seca	82-84	055019	120	94500-02120	CMM-G	219FTSSDHA	BF05M	385,-	481:-
XS 750	77-82	055022	124	94500-02124	CMM-G	219FTSSDHA	BF05M	410,-	513:-
XS 750 SE	79-82	055022	124	94500-02124	CMM-G	219FTSSDHA	BF05M	410,-	513:-
XTZ 750 Super Tenere	89-98	055048	138	94591-40138	CMM-A	SCA0412ASDH	82RH2015	695,-	869:-
XV 750 SE	81-83	055037	98	94590-27098	CMM-A	SCA0412ASDH	82RH2015	510,-	638:-
XV 750 Virago	92-97	055037	98	94590-27098	CMM-A	SCA0412ASDH	82RH2015	510,-	638:-

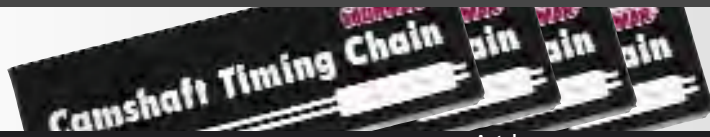

Made in Japan

Märke/ modell	Årg.	Varenr.	Antal led	OEM-nr.	Tourmax-nr.	DID-nr.	Borgvarna-nr.		
Märke/ modell	Årg.	Art.nr.	Antal länk.	OEM-nr.	Tourmax-nr.	DID-nr.	Borgvarna-nr.	DKK	SEK
YAMAHA									
YZF 750 R/SP	93-98	055013	104	94580-81104	CMM-G	219FTSSDHA	BF05M	338,-	423,-
FZ 8 N/S	10-11		124		CMM-FN				
TDM 850	91-01	055048	138	94591-40138	CMM-A	SCA0412ASDH	82RH2015	695,-	869,-
TRX 850	96-00	055048	138	94500-40138	CMM-A	SCA0412ASDH	82RH2015	695,-	869,-
XJ 900	83-94	055019	120	94500-02120	CMM-G	219FTSSDHA	BF05M	385,-	481,-
XJ 900 Diversion	95-03	055054	150	94591-40150	CMM-A	SCA0412ASDH	82RH2015	750,-	938,-
TDM 900	03-09	055048	138	94591-40138	CMM-A	SCA0412ASDH	82RH2015	695,-	869,-
XV 920	85>	055037	98	94590-27098	CMM-A	SCA0412ASDH	82RH2015	338,-	638,-
FZR 1000 Genesis	87-88	055015	110	94580-37110	CMM-G	219FTSSDHA	BF05M	350,-	438,-
FZR 1000 EXUP	89-97	055015	108	94581-01108	CMM-G	219FTSSDHA	BF05M	350,-	438,-
GTS 1000	93-98	055015	108	94581-01108	CMM-G	219FTSSDHA	BF05M	350,-	438,-
YZF 1000 Thunderace	96-01	055015	108	94581-01107	CMM-G	219FTSSDHA	BF05M	350,-	438,-
YZF-R1	98-03	055067	130	94591-60122	CMM-E	SCR0412SDH	92RH2015	715,-	894,-
YZF-R1	04-08	055085	122	94591-60124	CMM-Z	-	98XRH2020	465,-	581,-
YZF-R1	09-10		126		CMM-ZN				
FZS 1000 Fazer	01-05	055067	130	94591-49130	CMM-E	SCR0412SDH	92RH2015	715,-	894,-
FZ 1 N/S	06-10	055085	122	94591-60122	CMM-Z	-	98XRH2020	465,-	581,-
FZS 10/FZ1	08-09	055085	122	94591-60122	CMM-Z	-	98XRH2020	465,-	581,-
XV 1000 TR1	81-83	055037	98	94580-27098	CMM-A	SCA0412ASDH	82RH2015	510,-	638,-
XV 1000 Virago	86-89	055037	98	94590-27098	CMM-A	SCA0412ASDH	82RH2015	510,-	638,-
FJ 1100	84-85	055057	156	94590-69156	CMM-A	SCA0412ASDH	82RH2015	725,-	906,-
XS 1100 G/S	78-84	055022	128	94500-02128-05M	CMM-G	219FTSSDHA	BF05M	410,-	513,-
XV 1100 Virago	89-98	055037	98	94590-45098	CMM-A	SCA0412ASDH	82RH2015	510,-	638,-
XVS 1100 Drag Star	99-08	055077	98	94591-49098	CMM-E	SCR0412SDH	92RH2015	558,-	698,-
BT 1100 Bulldog	03-05	055037	98	94590-45098	CMM-A	SCA0412ASDH	82RH2015	510,-	638,-
FJ 1200	86-97	055057	156	94590-69156	CMM-A	SCA0412ASDH	82RH2015	725,-	906,-
V-Max 1200	85-95	055019	118	94580-81180	CMM-G	219FTSSDHA	BF05M	385,-	481,-
V-Max 1200	96-06	055019	118	94580-81180	CMM-G	219FTSSDHA	BF05M	385,-	481,-
XJR 1200	95-99	055057	156	94591-05156	CMM-A	SCA0412ASDH	82RH2015	725,-	906,-
XVZ 12 TD	85-87	055042	118	94590-44118	CMM-A	SCA0412ASDH	82RH2015	610,-	763,-
FJR 1300	03-10	055080	136	94591-49136	CMM-E	SCR0412SDH	92RH2015	715,-	894,-
XJR 1300	98-09	055057	156	94591-05156	CMM-A	SCA0412ASDH	82RH2015	725,-	906,-
XVS 1300 Drag Star	06-08	055085	132	94591-57132	CMM-Z	-	98XRH2020	465,-	581,-
XVZ 1300	96-08	055019	118	94580-81118	CMM-G	219FTSSDHA	BF05M	385,-	481,-
XVZ 13 AH Royal Star	88-96	055019	118	94580-81118	CMM-G	219FTSSDHA	BF05M	385,-	481,-
V-Max 1700	09-11	055080	134		CMM-E	SCR0412SDH	92RH2015	715,-	894,-

1



2

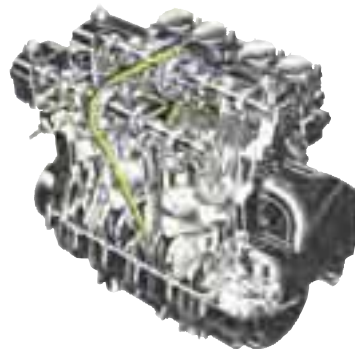

3

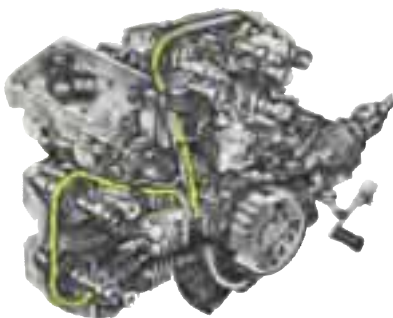

4

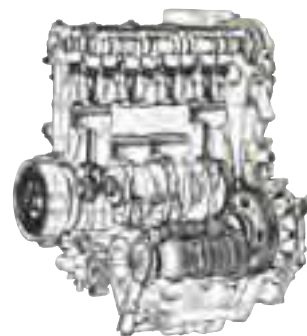

- Stikord
Sökord
s. 2-5
- Forhandlere
Återförsäljare
s. 6-9
- Tøj/hjelme
Kläder/
hjälmnar
s. 11
- Dæk
Däck
s. 83
- Olje
Olja
s. 115
- Kæde/
tandhjul
Kedjor/
drev
s. 145
- Bremser
Broms
s. 187
- Låse
Lås
s. 347
- Batteri
Batterier
s. 355
- Pakninger
Packningar
s. 377
- Motordele
Motordelar
s. 411**
- Lejer
Lager
s. 435
- Karburator
Förgasare
s. 467
- El-dele/
Tænding
Elektriskt/
Tænding
s. 509
- Blinklygter
Baglygter
Belysning
Baklygter
s. 611
- Lyddæmper
Avgassystem
s. 651
- Støddæmper
Støtdämpare
s. 681
- Luft/
oliefilter
Luft/
oljefilter
s. 711
- Kobling
Koppling
s. 769
- Kabler
Wire
s. 803
- Styr/greb
Styre/
handtag
s. 829
- Spejle
og diverse
Speglar
och diverse
s. 867
- Bøger/
værktøj
Böcker/
verktyg
s. 893

Knastkæder

Kæderne leveres i standard længder og du kan forvente at skulle afkorte og nitte kæderne.

Her anbefales kædeværktøj 08-058

Kamkedjor

Kedjorna levereras i standardlängder.

Du kan förvänta dig att du eventuellt måste korta av kedjan.

Till detta rekommenderas

kedjeverktyg 08-058



DID



Made in Japan

KÆDER/KEDJOR						SAMLELED/KEDJELÅS							
Varrenr.	Fabrikat	Tourmax nr.	DID nr.	Borgwama nr.	Antal led	Nitted DID Varenr.		NITTELED TOURMAX Varenr.		Ref.nr.			
Art.nr.	Fabrikat	Tourmax nr.	DID nr.	Borgwama nr.	Antal länkar	DKK	SEK	Art.nr.	DKK	SEK	Art.nr.	DKK	SEK
055001	DID		219T		88	218,-	273,-	056000	14,-	18,-		219T	
055003	DID		219T		94	255,-	319,-	056000	14,-	18,-		219T	
055004	DID		219T		122	299,-	374,-	056000	14,-	18,-		219T	
055006	DID		219T		128	326,-	408,-	056000	14,-	18,-		219T	
055007	DID	CMM-HD	219 FTH	BT 05 MA	116	345,-	431,-	056001	14,-	54,-		219FTH	
055009	DID	CMM-HD	219 FTH	BT 05 MA	122	335,-	419,-	056001	43,-	54,-		219FTH	
055013	TOURMAX	CCM-G	219 FTSS DHA	BF 05 M	106	338,-	423,-	056002	21,-	26,-	056025	BF 05 M	16,- 20,-
055015	TOURMAX	CCM-G	219 FTSS DHA	BF 05 M	110	350,-	438,-	056002	21,-	26,-	056025	BF 05 M	16,- 20,-
055016	TOURMAX	CCM-G	219 FTSS DHA	BF 05 M	114	365,-	456,-	056002	21,-	26,-	056025	BF 05 M	16,- 20,-
055019	TOURMAX	CCM-G	219 FTSS DHA	BF 05 M	120	385,-	481,-	056002	21,-	26,-	056025	BF 05 M	16,- 20,-
055020	TOURMAX	CCM-G	219 FTSS DHA	BF 05 M	122	387,-	484,-	056002	21,-	26,-	056025	BF 05 M	16,- 20,-
055022	TOURMAX	CCM-G	219 FTSS DHA	BF 05 M	128	410,-	513,-	056002	21,-	26,-	056025	BF 05 M	16,- 20,-
055024	TOURMAX	CMM-B	SCA 0409 ASDH	82RH 2010	118	510,-	638,-	056003	23,-	29,-	056026	CMM-B	20,- 25,-
055027	TOURMAX	CMM-B	SCA 0409 ASDH	82RH 2010	138	595,-	744,-	056003	23,-	29,-	056026	CMM-B	20,- 25,-
055029	TOURMAX	CMM-B	SCA 0409 ASDH	82RH 2010	144	650,-	813,-	056003	23,-	29,-	056026	CMM-B	20,- 25,-
055031	TOURMAX	CMM-A	SCA 0412 ASDH	82RH 2015	82	385,-	481,-	056005	21,-	26,-	056027	CMM-A	26,- 33,-
055037	TOURMAX	CMM-A	SCA 0412 ASDH	82RH 2015	110	510,-	638,-	056005	21,-	26,-	056027	CMM-A	26,- 33,-
055040	TOURMAX	CMM-A	SCA 0412 ASDH	82RH 2015	116	585,-	731,-	056005	21,-	26,-	056027	CMM-A	26,- 33,-
055042	TOURMAX	CMM-A	SCA 0412 ASDH	82RH 2015	120	610,-	763,-	056005	21,-	26,-	056027	CMM-A	26,- 33,-
055045	TOURMAX	CMM-A	SCA 0412 ASDH	82RH 2015	128	645,-	806,-	056005	21,-	26,-	056027	CMM-A	26,- 33,-
055048	TOURMAX	CMM-A	SCA 0412 ASDH	82RH 2015	138	695,-	869,-	056005	21,-	26,-	056027	CMM-A	26,- 33,-
055054	TOURMAX	CMM-A	SCA 0412 ASDH	82RH 2015	150	750,-	938,-	056005	21,-	26,-	056027	CMM-A	26,- 33,-
055056	TOURMAX	CMM-A	SCA 0412 ASDH	82RH 2015	154	710,-	888,-	056005	21,-	26,-	056027	CMM-A	26,- 33,-
055057	TOURMAX	CMM-A	SCA 0412 ASDH	82RH 2015	156	725,-	906,-	056005	21,-	26,-	056027	CMM-A	26,- 33,-
055058	TOURMAX	CMM-A	SCA 0412 ASDH	82RH 2015	160	725,-	906,-	056005	21,-	26,-	056027	CMM-A	26,- 33,-
055059	TOURMAX	CMM-A	SCA 0412 ASDH	82RH 2015	174	695,-	869,-	056005	21,-	26,-	056027	CMM-A	26,- 33,-
055060	TOURMAX	CMM-P	SCO 417 HDHA	75RM 2025	78	605,-	756,-	056007	21,-	26,-	056028	CMM-P	26,- 33,-
055061	TOURMAX	CMM-P	SCO 417 HDHA	75RM 2025	148	1030,-	1288,-	056007	21,-	26,-	056028	CMM-P	26,- 33,-
055062	DID	CMM-C	SC 2515 DHA	81RH 2515	118	670,-	838,-	056008	21,-	26,-		CMM-C	
055063	DID	CMM-C	SC 2515 DHA	81RH 2515	148	665,-	831,-	056008	21,-	26,-		CMM-C	
055064	TOURMAX	CMM-W	0 5 T	BF 05T	118	260,-	325,-	056009	42,-	53,-	056029	CMM-W	16,- 20,-
055065	DID	CMM-S	215 FDHA	-	110	350,-	438,-	056010	32,-	40,-		CMM-S	
055066	TOURMAX	CMM-SD	215 FDHA	-	118	550,-	688,-	056010	32,-	40,-		CMM-SD	
055067	TOURMAX	CMM-E	SCR 0412 SDH	92RH2015	130	715,-	894,-				056011	CMM-E	21,- 26,-
055068	TOURMAX	CMM-J	SCR 0409 SDH	92RH 2010	130	485,-	606,-				056012	CMM-J	21,- 26,-
055069	TOURMAX	CMM-E	SCR 0412 SDH	92RH2015	92	425,-	531,-				056011	CMM-E	21,- 26,-
055070	TOURMAX	CMM-J	SCR 0409 SDH	92RH 2010	120	458,-	573,-				056012	CMM-J	21,- 26,-
055071	TOURMAX	CMM-U	25 H	-	88	198,-	248,-					CMM-U	
055072	TOURMAX	CMM-E	SCR 0412 SDH	92RH2015	104	588,-	735,-				056011	CMM-E	21,- 26,-
055073	TOURMAX	CMM-E	SCR 0412 SDH	92RH2015	112	565,-	706,-				056011	CMM-E	21,- 26,-
055074	TOURMAX	CMM-J	SCR 0409 SDH	92RH 2010	114	560,-	700,-				056012	CMM-J	21,- 26,-
055075	TOURMAX	CMM-FF	-	98XRH 2010	118	673,-	841,-					CMM-FF	
055076	TOURMAX	CMM-J	SCR 0409 SDH	92RH 2010		198,-	248,-				056012	CMM-J	21,- 26,-
055077	TOURMAX	CMM-E	SCR 0412 SDH	92RH2015	116	558,-	698,-				056011	CMM-E	21,- 26,-
055078	TOURMAX	CMM-E	SCR 0412 SDH	92RH2015	152	838,-	1048,-				056011	CMM-E	21,- 26,-
055079	TOURMAX	CMM-J	SCR 0409 SDH	92RH 2010	144	635,-	794,-				056012	CMM-J	21,- 26,-
055080	TOURMAX	CMM-E	SCR 0412 SDH	92RH2015	148	715,-	894,-				056011	CMM-E	21,- 26,-
055081	TOURMAX	CMM-B	SCA 0409 ASDH	82RH 2010	158	595,-	744,-				056012	CMM-B	21,- 26,-
055082	TOURMAX	CMM-E	SCR 0412 SDH	92RH2015	174	760,-	950,-				056011	CMM-E	21,- 26,-
055083	TOURMAX	CMM-W	0 5 T	BF 05T	130	415,-	519,-	056009	42,-	53,-	056029	CMM-W	16,- 20,-
055084	TOURMAX	CMM-J	SCR 0409 SDH	92RH 2010	92	415,-	519,-				056012	CMM-J	21,- 26,-
055085	TOURMAX	CMM-FF	-	98XRH 2010	132	465,-	581,-					CMM-FF	

HYOSUNG

made in Korea

GT 250 racer



8001039 Hvid

Motor: Luft/oliekolet, DOHC, 8 ventiler, 75° V-twin.

Slagvolumen: 249 cc.

Boring og slaglængde: 57 x 48,8.

Kompression: 10,3 : 1.

Max ydelse: 29 HK.

Max drejningsmoment: 21,04 Nm ved 6750 omdr./min.

Brændstofsysteem: Direkte indsprøjtning.

Smøring: Våd sump.

Kobling: Våd flerpladet.

Gear: Fem manuelle (1 ned resten op).

Bremser: For: To 300 mm skiver. Bag: En 230 mm skive.

Affjedring: For: 41 mm upsidedown forgaffel.

Bag: svingarm med hydraulisk monodæmper. Justérbar.

Dæk: For: 110/70-17 54H. Bag: 150/70-17 69H.

LxBxH: 2090 x 700 x 1130 mm.

Akselafstand: 1435 mm.

Frihøjde: 155 mm.

Sædehøjde: 830 mm.

Drivline: Kæde.

Vægt: 188 kg.



46.995,-

Excl. leveringsomkostninger



Hyosung anbefaler olie fra
Silkolene



Find nærmeste forhandler og læs mere på

www.hyosung.dk 

Meget mere motorcykel for pengene! ...

🇩🇰 Bundkæde

Japanske bundkæder i topkvalitet!

Bundkæderne fra japanske Tourmax er ligesom knastkæderne fremstillet i højeste kvalitet. Bundkæderne leveres til en række motorcykler på markedet, og er 100 % et OEM produkt.



Made in Japan

🇯🇵 Transmissions kedjor

Japanska transmissionkedjor i topkvalitet!

Dessa kedjor från japanska TourMAX, är precis som kamkedjorna tillverkade i högsta kvalitet. Transmissions kedjorna finns till en lång rad motorcyklar på marknaden och är till 100 % en OEM produkt.

Mærke/ model	Årg.	Varenr.	Ref.nr.	OEM-nr.		
Märke/ modell	Årg.	Art.nr.	Ref.nr.	OEM-nr.	DKK	SEK
HONDA						
CB 350 F	72-74	057000	PCM-403	23131-323-003	1313,-	1641,-
CB 400 F	75-78	057000	PCM-403	23131-323-003	1313,-	1641,-
CBX 400 F1/F2	82-86	057017		13610-MA6-000	1520,-	1900,-
CB 500 Four/F/K	70-76	057000	PCM-403	23131-323-003	1313,-	1641,-
CB 550 K/F	76-78	057000	PCM-403	23131-323-003	1313,-	1641,-
CBX 550 F1/F2	82-86	057017		13610-MA6-000	1520,-	1900,-
CB 650/C	78-83	057000	PCM-403	23131-323-003	1313,-	1641,-
CB 750 F Bol'Dor	79-82	057002	PCM-106	13610-393-001	1701,-	2126,-
CB 750 K0-7						
F1-F2	69-78	057001		23131-300-015	426,-	533,-
CB 750 KZ	79-82	057002	PCM-106	13610-393-001	1701,-	2126,-
CB 900 F Bol'Dor	79-83	057003	PCM-104	13610-438-004	1763,-	2204,-
CBX 1000	78-83	057018		23131-422-004	1363,-	1704,-
GL 1000	75-79	057004	PCM-102	23131-371-004	2046,-	2558,-
CB 1100 F/R	83	057005	PCM-103	13610-MA3-003	2159,-	2699,-
GL 1100	80-83	057006	PCM-101	23131-463-003	2497,-	3121,-
GL 1200	84-87	057006	PCM-101	23131-463-003	2497,-	3121,-
KAWASAKI						
Z 400 B, 2-cyl.	74-79	057019		13122-005	1363,-	1704,-
Z 400 J, 4-cyl.	80-84	057000	PCM-403	92057-1011	1313,-	1641,-
Z 440 /LTD	80-84	057019		13122-005	1363,-	1704,-
Z 450 LTD	85-89	057008	PCM-404	92057-1187/1229	1892,-	2365,-
EN 500	90>	057008	PCM-404	92057-1187/1229	1892,-	2365,-
ER 5 Twister	97>	057008	PCM-404	92057-1187/1229	1892,-	2365,-
GPZ 500 S	87>	057008	PCM-404	92057-1187/1229	1892,-	2365,-
KLE 500	91>	057008	PCM-404	92057-1187/1229	1892,-	2365,-
Z 500 B	79-80	057000	PCM-403	92057-1011	1313,-	1641,-
GPZ 550 Unitrak	84-89	057000	PCM-403	92057-1011	1313,-	1641,-
GT 550	83-89	057000	PCM-403	92057-1011	1313,-	1641,-
Z 550 F	80-83	057000	PCM-403	92057-1011	1313,-	1641,-
ZR 550 Zephyr	91-99	057000	PCM-403	92057-1011	1313,-	1641,-
GPX 600 R	88-99	057000	PCM-403	92057-1011	1313,-	1641,-
GPZ 600 R	85-90	057000	PCM-403	92057-1011	1313,-	1641,-
ZL 600 Eliminator	86-97	057000	PCM-403	92057-1011	1313,-	1641,-
Z 650 B	77-79	057003	PCM-104	13122-007	1763,-	2204,-
Z 650 CSR	81-83	057003	PCM-104	13122-007	1763,-	2204,-
Z 650 F	80-83	057003	PCM-104	13122-007	1763,-	2204,-
Z 650 LTD	80-83	057003	PCM-104	13122-007	1763,-	2204,-
GPZ 750	82	057003	PCM-104	13122-007	1763,-	2204,-
GPZ 750 Unitrak	83-85	057003	PCM-104	13122-007	1763,-	2204,-
GPZ 750 Turbo	84-85	057022		92057-1075/1151	1289,-	1611,-
GT 750	82-85	057003	PCM-104	13122-007	1763,-	2204,-
Z 750	81-83	057003	PCM-104	13122-007	1763,-	2204,-
Z 750 E	80-82	057003	PCM-104	13122-007	1763,-	2204,-
Z 750 LTD, 4-cyl.	80-83	057003	PCM-104	13122-007	1763,-	2204,-
Z 750 LTD, 2-cyl.	80-84	057007	PCM-408	13122-008	2586,-	3233,-
ZR 7/S	99>	057003	PCM-104	13122-007	1763,-	2204,-
ZR 750 Zephyr	91-99	057003	PCM-104	13122-007	1763,-	2204,-
Z 1300	79-83	057020		92057-1016	1573,-	1966,-
Z 1300	79-83	057021		92057-1017	1678,-	2098,-
Z 1300 DFI	84-89	057022		92057-1075/1151	1289,-	1611,-
Z 1300 DFI	84-89	057023		92057-1127	1468,-	1835,-

Mærke/ model	Årg.	Varenr.	Ref.nr.	OEM-nr.		
Märke/ modell	Årg.	Art.nr.	Ref.nr.	OEM-nr.	DKK	SEK
YAMAHA						
XS 400 DOHC	82-83	057009	PCM-207	12R-11456-01	1001,-	1251,-
XJ 550	81-83	057010	PCM-204	4G0-16139-00	1486,-	1858,-
XJ 600	84-91	057010	PCM-204	4G0-16139-00	1486,-	1858,-
XJ 600 Diversion	92>	057012	PCM-208	4BR-16139-00	1546,-	1933,-
XJ 650	80-85	057011	PCM-203	4H7-11456-00	1081,-	1351,-
XJ 650 Turbo	82-84	057011	PCM-203	4H7-11456-00	1081,-	1351,-
FZ 750	85-93	057014	PCM-201	36Y-11456-00	1040,-	1300,-
FZX 750 Fazer	86-89	057014	PCM-201	36Y-11456-00	1040,-	1300,-
XJ 750 /Seca	81-84	057011	PCM-203	4H7-11456-00	1081,-	1351,-
XS 750	78-79	057013	PCM-206	1J7-16139-04	2448,-	3060,-
XS 750 US Custom	80-82	057013	PCM-206	1J7-16139-04	2448,-	3060,-
YZF 750 R/SP	93-98	057015	PCM-209	4FM-11456-00	1040,-	1300,-
XS 850	80-82	057024		3J2-16139-00	2308,-	2885,-
XJ 900	83-94	057011	PCM-203	4H7-11456-00	1081,-	1351,-
FZR 1000	87-88	057014	PCM-201	36Y-11456-00	1040,-	1300,-
FZR 1000 Exup	89-93	057014	PCM-201	36Y-11456-00	1040,-	1300,-
FZR 1000 Exup	94-95	057015	PCM-209	4FM-11456-00	1040,-	1300,-
GTS 1000	93-98	057011	PCM-203	4H7-11456-00	1081,-	1351,-
FJ 1100	84-85	057014	PCM-201	36Y-11456-00	1040,-	1300,-
XS 1100	78-82	057016	PCM-202	2H7-16139-02	2243,-	2804,-
YZF 1000 Th.race	96>	057015	PCM-209	4FM-11456-00	1040,-	1300,-
FJ 1200	86-96	057014	PCM-201	36Y-11456-00	1040,-	1300,-
XJR 1200	95-98	057015	PCM-209	4FM-11456-00	1040,-	1300,-
XJR 1300	99>	057015	PCM-209	4FM-11456-00	1040,-	1300,-

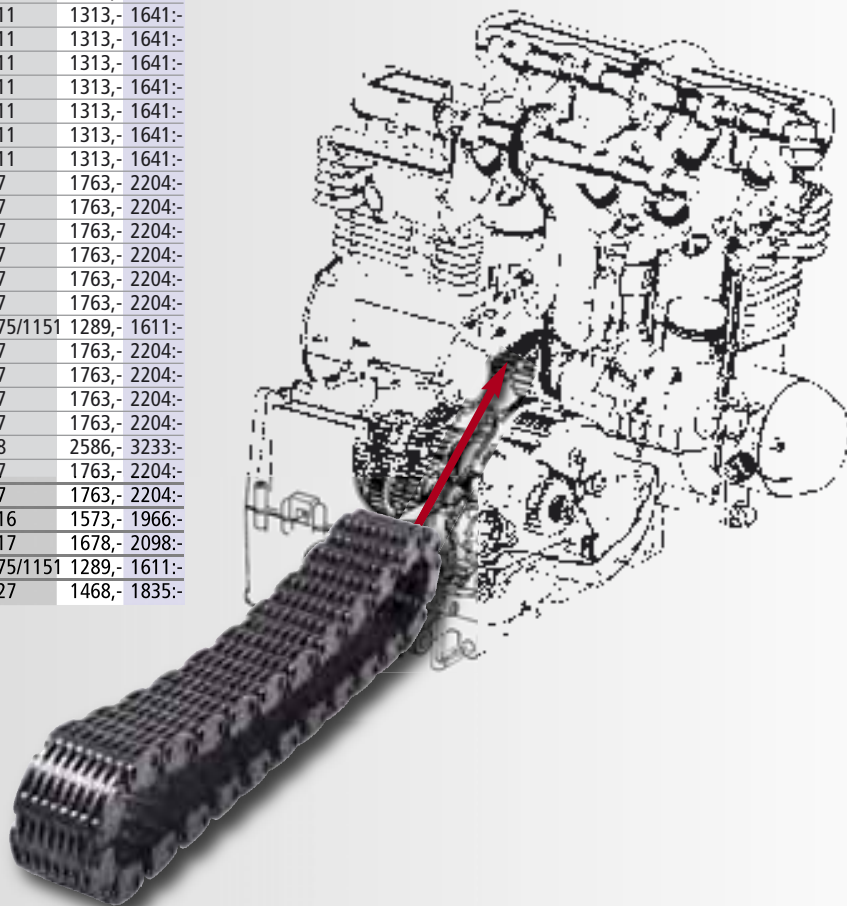

DK Knastkæde strammerkit
Ekstra forstærkede knastkæde strammerkit
til Kawasaki.

SE Kamkedja reparationsats
Extra starkt rep.kit innehållande fyra delar
för sträckning av kamkedjan till Kawasaki.



Made in Japan

Mærke/ model	Årg.	KNASTKÆDE STRAMMERKIT Varenr.	Ref.nr.		
Märke/ modell	Årg.	KAMKEDJA REPARATIONSATS Art.nr.	Ref.nr.	DKK	SEK
KAWASAKI					
GPZ 400 Unitrak (ZX400A)	84-85	057102	PRK-103	169,-	211,-
Z 400 F (4-cyl.) (KZ400J)	84	057102	PRK-103	169,-	211,-
Z 400 GP (4-cyl.) (KZ400M)	83	057102	PRK-103	169,-	211,-
Z 400 J (4-cyl.) (KZ400J)	80-82	057102	PRK-103	169,-	211,-
Z 500B (KZ500B)	79-80	057102	PRK-103	169,-	211,-
GPZ 550, Z 550 GP (KZ550H)	82-83	057102	PRK-103	169,-	211,-
GPZ 550 Unitrak (ZX550A)	84-89	057102	PRK-103	169,-	211,-
GT 550, Z 550 GT (KZ550G)	83-94	057102	PRK-103	169,-	211,-
Z 550 (KZ550B)	81-82	057102	PRK-103	169,-	211,-
Z 550 F Unitrak (KZ550B-B)	83-84	057102	PRK-103	169,-	211,-
Z 550 GP (KZ550D)	81	057102	PRK-103	169,-	211,-
Z 550 LTD (KZ550C)	80-89	057102	PRK-103	169,-	211,-
ZR 550 (KZ550A)	80-83	057102	PRK-103	169,-	211,-
Z 650 F (KZ650F)	80-83	057101	PRK-102	169,-	211,-
Z 650 CSR (KZ650H)	81-83	057101	PRK-102	169,-	211,-
Z 650 LTD (KZ650E, L)	80-83	057101	PRK-102	169,-	211,-
GPZ 750 (KZ750R1)	82	057101	PRK-102	169,-	211,-
GPZ 750 Unitrak (ZX750A)	83-89	057101	PRK-102	169,-	211,-
GPZ 750 Turbo (ZX750E)	84-85	057101	PRK-102	169,-	211,-
Z 750 E (KZ750E)	80-82	057101	PRK-102	169,-	211,-
Z 750 GP (R1) (KZ750R)	82	057101	PRK-102	169,-	211,-
Z 750 GT Kardan (KZ750P)	82-85	057101	PRK-102	169,-	211,-
Z 750 (L3, L4) (KZ750R)	83-84	057101	PRK-102	169,-	211,-
Z 750 LTD (4-cyl.) (KZ750H)	80-82	057101	PRK-102	169,-	211,-
Z 1000 J (KZ1000J) (KZT00J)	81-82	057100	PRK-101	169,-	211,-
Z 1000 LTD (KZ1000K) (KZT00K)	81-83	057100	PRK-101	169,-	211,-
Z 1000 Police (KZ1000P) (KZT00P)	82-96	057100	PRK-101	169,-	211,-
Z 1000 R1, R2 (KZ1000R) (KZT00R)	82-83	057100	PRK-101	169,-	211,-
GPZ 1100 Pre-Unitrak (KZT10B)	81-82	057100	PRK-101	169,-	211,-
GPZ 1100 Unitrak (ZXT10A)	83-85	057100	PRK-101	169,-	211,-
Z 1100 GP (KZ1100B1,2) (KZT10B)	81-82	057100	PRK-101	169,-	211,-
Z 1100 ST (KZ1100A) (KZT10A)	81-83	057100	PRK-101	169,-	211,-

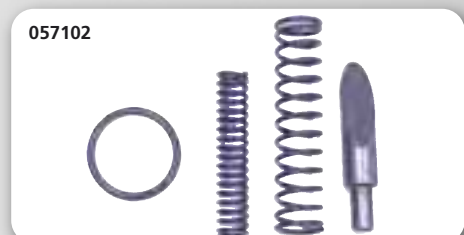

DK Kædenitteværktøj

Dette værktøj kan samle en kæde til en endeløs kæde. Både til knast- og bagkæder. Værktøjet kan også bruges til at presse nitten ud. Værktøjsættet indeholder tre størrelser dorne og presseværktøj.

SE Kedjenitverktyg

Med detta verktyg kan du sätta ihop en oändlig lång kedja om du vill. Både till kamkedjor och bakhjul. Verktyget kan också användas till pressa ur nitar med. Satsen innehåller pressverktyg samt tre storlekar på dorn.



	DKK	SEK
Med alle dorne. Varenr./art.nr. 08-058	487,-	609,-
<i>Ekstra dorne:</i>		
2 mm dorn Varenr./art.nr. 08-059	68,-	85,-
3 mm dorn Varenr./art.nr. 08-060	68,-	85,-
4 mm dorn Varenr./art.nr. 08-061	68,-	85,-
Nittedorn: Varenr./art.nr. 08-062	82,-	103,-

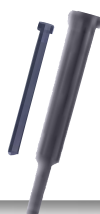

- Stikord Sökord s. 2-5
- Forhandlere Aterförsäljare s. 6-9
- Tøj/hjelme Kläder/hjälmar s. 11
- Dæk Däck s. 83
- Oljeolja s. 115
- Kæde/tandhjul Kedjor/drev s. 145
- Bremser Broms s. 187
- Låse Lås s. 347
- Batteri Batterier s. 355
- Pakninger Pakningar s. 377
- Motordele Motordelar s. 411**
- Lejer Lager s. 435
- Karburator Förgasare s. 467
- El-dele/Tænding Elektriskt/Tänding s. 509
- Blinklygter Baglygter Belysning Baklygter s. 611
- Lyddæmper Avgassystem s. 651
- Støddæmper Stötdämpare s. 681
- Luft/oliefilter Luft/oljefilter s. 711
- Kobling Koppling s. 769
- Kabler Wire s. 803
- Styr/greb Styre/handtag s. 829
- Spejle og diverse Speglar och diverse s. 867
- Bøger/værktøj Böcker/verktyg s. 893

✚ Kølertermostater

Har din motorcykel problemer med overophedning eller meget lang opvarmningsperiode? Skift til en topkvalitets kølertermostat fra Tourmax.
Made in Japan og i original kvalitet!

✚ Termostater

Har du problem med overhettning eller att det tar alltför lång tid innan motorn blir riktigt varm? Byt till en Tourmax termostat.
Made in Japan och i original kvalitet!



Made in Japan

Mærke/ model	Årg.	Kølertermostater · Thermostat				
Mærke/ modell	Årg.	Varenr.	Ref.nr.	OEM-nr.		
HONDA						
CBR 900 RR	98	221001	TM-1002	19300-MAS-E00	326,-	408,-
KAWASAKI						
KL 650 A1-A12 KLR 650	87-03	221101	TM-4003	49054-1053	326,-	270,-
KLX 650 C1/C2/C3 KLX 650	93-96	221101	TM-4003	49054-1053	326,-	270,-
SUZUKI						
TL 1000	97-98	221200	TM-3001	17670-12C00	242,-	303,-
YAMAHA						
RD 350 YPVS	84-85		TM-2004	29L-12411-00		
FZR 400 R/U/SCUW/SWC 1	87-89	221305	TM-2007	46X-12410-00	209,-	261,-
FZR 400 SAC	90	221305	TM-2007	46X-12410-00	209,-	261,-
FZR 600 ALLE	88-98	221305	TM-2007	46X-12410-00	209,-	261,-
YZF 600 RG/RGC/RH/RHC/RJ/RJC/RK/RKC	95-03	221307	TM-2009	4JH-12410-00	209,-	261,-
XJ 700 NC/SC/XS/XSC	85-86	221301	TM-2002	1AA-12410-00	209,-	261,-

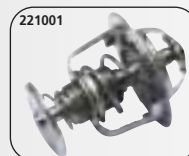

✚ Plejstangkit ✚ Vevstaks sats

Mærke/ model	Type	Plejstangkit			
Mærke/ modell	Type	Varenr.	Stør.		
HONDA					
MTX/NSR 125	-KE1-	137003	498,-	623,-	
XL 250 S		137004	798,-	998,-	
NX/XR 650 Dominator	-MN9-	137008	1298,-	1623,-	
MZ					
MZ 125 ETZ	Alle	137400	748,-	935,-	
MZ 250 ETZ	Alle	137401	848,-	1060,-	
YAMAHA					
RD 350 YPVS	Alle	137311	683,-	854,-	



✚ Nålelejer ✚ Nållager

Mærke/ model	Type	Nålelejer			
Mærke/ modell	Type	Varenr.	Stør.		
YAMAHA					
RD/DT 125	Alle	134019	16x20x19	90,-	113,-
RD/DT 125 LC/YPVS	Alle	134019	16x20x19	90,-	113,-
TZR 125/250	Alle	134015	16x21x19	118,-	148,-
DT 175 AIR	Alle	134016	16x21x20	90,-	113,-
RD 250/350	Alle	134016	16x21x20	90,-	113,-
TRX 250	Alle	134003	18x22x22	90,-	113,-
RD 350 LC/YPVS	Alle	134017	16x21x22	90,-	113,-



Made in Japan



HYOSUNG

made in Korea

RT 125 D off road

Motor: Luft/oliekolet, DOHC, 4 ventiler, 1 cylinder.
Slagvolumen: 124,5 cc.
Boring og slaglængde: 57 x 48,8.
Kompression: 11,3 : 1.
Max ydelse: 13,6 HK.
Max drejningsmoment: 10,89 Nm ved 800 omdr./min.
Brændstofsistem: Karburator.
Smøring: Våd sump.
Kobling: Våd flerpladet.
Gear: Fem manuelle (1 ned resten op).
Bremser: For: En 275 mm skive. Bag: Tromle.
Affjedring: For: Almindelig forgaffel.
Bag: svingarm med hydraulisk monodæmper. Justérbar.
Dæk: For: 130/80-18 66P. Bag: 180/80-14 78P.
LxBxH: 2085 x 840 x 1125 mm.
Akselafstand: 1350 mm.
Frihøjde: 230 mm.
Sædehøjde: 790 mm.
Drivline: Kæde.
Vægt: 135 kg.

Hyosung anbefaler olie fra
Silkolene

24.995,-

Excl. leveringsomkostninger



8001027 Blå



Find nærmeste forhandler og læs mere på
www.hyosung.dk 

Meget mere motorcykel for pengene! ...