

ISSUE NO. : 10-004	DATE : Mar 4th. 2010	PAGES : 1 OF 1
--------------------	----------------------	----------------

SUBJECT	<b>Notice of GEAR COMP, STARTER CLUTCH Modification</b>
MODEL	GT250, GV250
EFFECTIVE F/M NO	Attached

This service bulletin is written to inform you of GEAR COMP, STARTER CLUTCH modification.

### 1. Purpose

- To announce a modification of GEAR COMP, STARTER CLUTCH.

### 2. Details

#### 1) Modification of GEAR COMP, STARTER CLUTCH

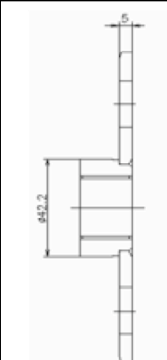
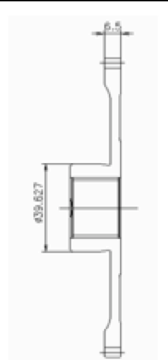
		Before	After
Part No.		12620HJ8204	12620H98600
Detail	①Size of CLUTCH, STARTER ONE WAY assembly part → $\Phi 42.2$ ②Thickness of GEAR part → 5.0		

#### 2) Modification of CLUTCH, STARTER ONE WAY which is assembled to GEAR COMP, STARTER CLUTCH.

		Before	After
Part No.		12614HS5000	12614H98600

→Please make sure to use 12614H98600(improved) when you replace fault part with 12620H98600.  
 Improved part is not matching for unimproved one.

### 3. Application

Model	VIN No	ENGINE No	Application date
GV250	KM4MJ54A8A1500897	GV250-135054	24/02/10

### 4. NOTE

→GT250 has not been applied. It will be informed with application.

- The End -